

Sizes 3/8" / 10 mm
Pressure Reducing Pilot Valve

Materials (Unleaded)

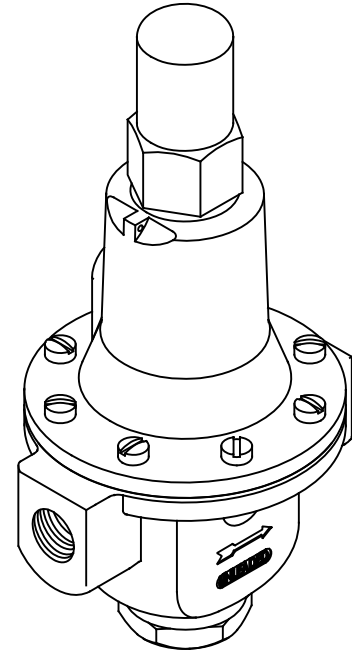
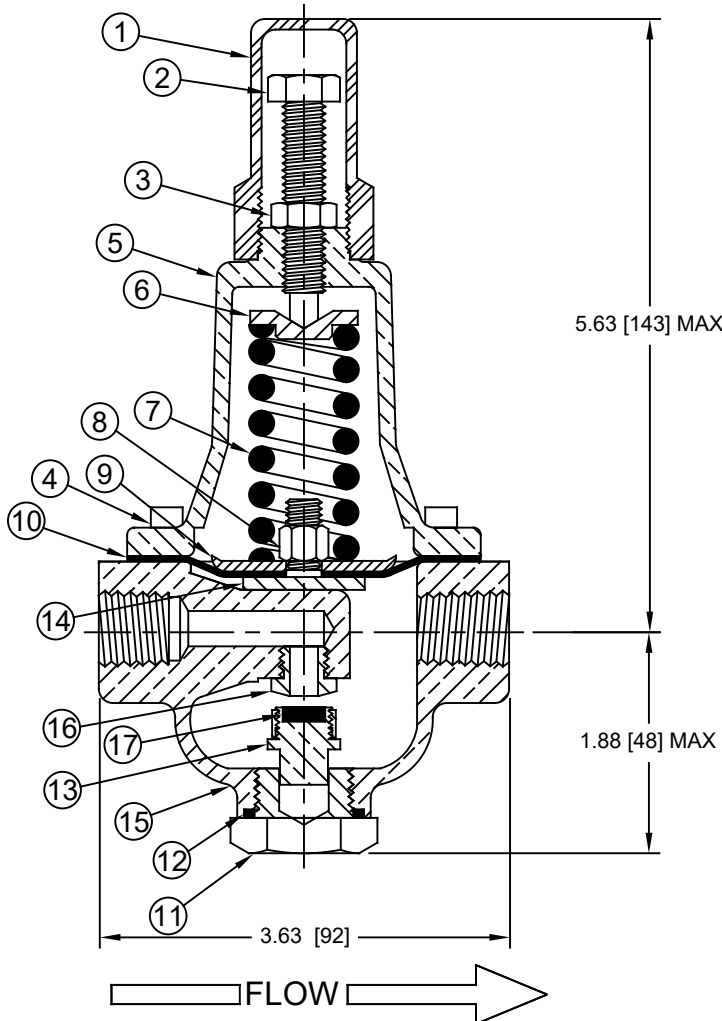
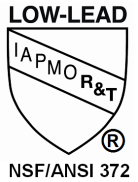

PILOT TYPE			
PSI RANGE	FACTORY SET @ PSI	SPRING NUMBER	ASSEMBLY NUMBER
5-80	30	9600397A	152100A
25-125	60	9600397B	152100B
2-35	15	9676000	152100C
30-300	60	9600397D	152100D

FNPT ANSI B1.20.1

Max Temp 180°F (82°C)
Max Pressure 400psi (28bar)

Item #	Qty	Description	Material	Item #	Qty	Description	Material
1	1	Adjustment Cap	ABS	10	1	Diaphragm	Buna-n/Nylon
2	1	Adjusting Screw	Stainless Steel 18-8	11	1	Body Plug	Brass C36000
3	1	Jam Nut	Stainless Steel 18-8	12	1	O-Ring	Buna-n
4	8	Socket Head Cap Screw	Stainless Steel 18-8	13	1	Disc Retainer	Unleaded Bronze C89833
5	1	Cover	Unleaded Bronze C89833	14	1	Yoke	Unleaded Bronze C89833
6	1	Spring Button	Stainless Steel 304	15	1	Body	Unleaded Bronze C89833
7	1	Spring	Steel (music wire)	16	1	Seat Ring	Stainless Steel 304
8	1	Nut	Stainless Steel 303	17	1	Disc	Buna-n
9	1	Diaphragm Plate	Stainless Steel 316	N/A	1	3/8" Plug (not shown) Optional	Brass

Flomatic Corporation can accept no responsibility for possible errors in catalogues, brochures and other printed material. Flomatic Corporation reserves the right to alter its products without notices. This also applies to product already agreed. All trademarks in this material are property of the respective companies. All rights reserved. ©2024 Flomatic Corporation. The drawings & information on this drawing sheet are the sole & exclusive property of Flomatic Corporation. Any reproduction, distribution, display or use of these drawings or information in whole or in part without written authorization of Flomatic Corporation is strictly prohibited. www.flomatic.com