

Foot Valve

Sizes 1-1/4" / 32 mm

Model 600SE



Flomatic Corporation

Materials

Enviro Check®

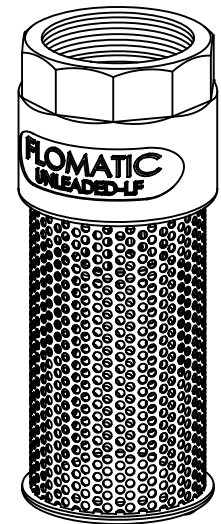
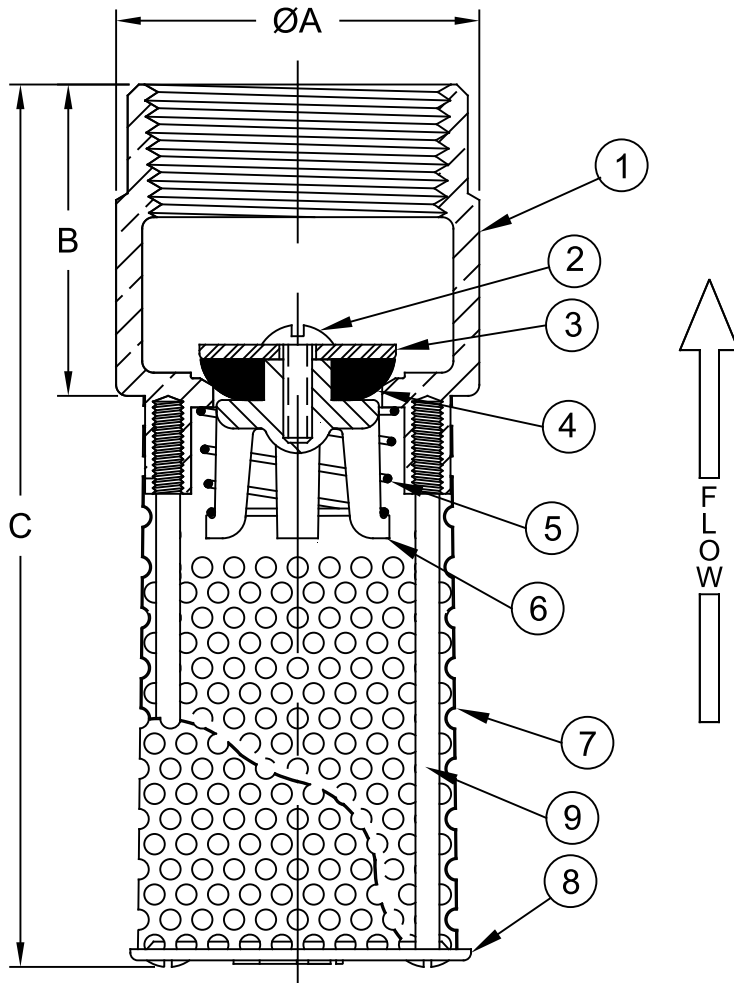

Max Temp 180°F (82°C)
Max Pressure 250psi (18bar)

Item #	Qty	Description	Material	ASTM
1	1	Body	Unleaded Bronze	C89833
2	1	Screw	Stainless Steel	18-8
3	1	Flat Washer*	Stainless Steel	18-8
4	1	Disc	Buna-n	N-5007
5	1	Spring	Stainless Steel	302
6	1	Guide	Delrin 100	NC010
7	1	Screen	Stainless Steel	304
8	1	Cap	Polycarbonate	-----
9	2	Screw	Stainless Steel	18-8

Washer material is 18-8SS or 304SS
Patent # 4,971,093

Dimensions (FNPT)

ANSI B1.20.1

Size		Part #	ØA		B		C		NPT	Weight	
inch	mm		inch	mm	inch	mm	inch	mm		lbs	kg
1-1/4	32	4102E	1.94	49	1.63	41	4.84	123	1-1/4	.85	.39

Flomatic Corporation can accept no responsibility for possible errors in catalogues, brochures and other printed material. Flomatic Corporation reserves the right to alter its products without notices. This also applies to product already agreed. All trademarks in this material are property of the respective companies. All rights reserved. ©2025 Flomatic Corporation. The drawings & information on this drawing sheet are the sole & exclusive property of Flomatic Corporation. Any reproduction, distribution, display or use of these drawings or information in whole or in part without written authorization of Flomatic Corporation is strictly prohibited. www.flomatic.com



May 28, 2006
Dwg No: S4102E Rev: L (5/24)

FLOMATIC CORPORATION
GLENS FALLS, N.Y. 12801
PHONE (518) 761-9797
FAX (518) 761-9798