

## **Swing Check Valve 745 Flo-Flex®**

*Industrial and Municipal Applications*

- Model 745
- Model 745 BF
- Model 745 PI
- Model 745 BFPI



**Flomatic Valves**

*High Quality Valves Built to Last...*

# Flo - Flex® Model 745 Swing Check Valve

The proven **Model 745** is the latest additional to the growing **Flo-Flex®** family of our rubber disc swing check valves. **Flo-Flex®** provides the water and wastewater industry one of the broadest line of rubber flexible disc swing checks available on the market today. The flange to flange lay length is according to ANSI / AWWA C508-01. **2" thru 24" sizing**



**745**

**745- 45° Seat Flo-Flex®**, Swing Check Valve Epoxy coated Ductile Iron Body, 125/150# Flanged, ANSI/AWWA C508, Buna-N coated steel disc.

**Temp Max: 140°F (60C)**

**Pressure Max: 250 PSI: 3"-12"**

**Pressure Max: 175 PSI: 14"- 24"**



**745PI**

**745 WITH POSITION INDICATOR- 45° Seat Flo-Flex®**, Swing Check Valve Epoxy coated Ductile Iron Body, 150/125# Flanged, ANSI/AWWA C508, Buna-N coated steel disc.

**Temp Max: 140°F (60C)**

**Pressure Max: 250 PSI: 3"-12"**

**Pressure Max: 175 PSI: 14"- 24"**



**745BF**

**745 WITH BACKFLUSH DEVICE- 45° Seat Flo-Flex®**, Swing Check Valve Epoxy coated Ductile Iron Body, 150/125# Flanged, ANSI/AWWA C508, Buna-N coated steel disc.

**Temp Max: 140°F (60C)**

**Pressure Max: 250 PSI: 3"-12"**

**Pressure Max: 175 PSI: 14"- 24"**



**745BFPI**

**745 WITH POSITION INDICATOR AND BACKFLUSH DEVICE- 45° Seat Flo-Flex®**, Swing Check Valve Epoxy coated Ductile Iron Body, 150/125# Flanged, ANSI/AWWA C508, Buna-N coated steel disc.

**Temp Max: 140°F (60C)**

**Pressure Max: 250 PSI: 3"-12"**

**Pressure Max: 175 PSI: 14"- 24"**

## Industrial and Municipal Applications



When a tight seal is critical.

Minimize system pressure drop.

Ideal In systems where flow is constant.

When horizontal or vertical line installation is required.

Where In-line maintenance is a must.



**Flomatic Valves**

*High Quality Valves Built to Last...*

# THE NEW HEAVY DUTY 745



## Features / Benefits

- Fusion epoxy coated inside/outside
- Flange to flange dimension according to AWWA C508-01
- The 45° angle valve seat
- Disc strokes 35° angle to minimize disc slam
- Low head loss
- Long rubber disc life
- Easy in-line serviceability
- Can be installed in vertical up flow or horizontal direction
- Precision molded valve disc of one piece construction, integral "o"-ring type sealing
- Can be used as pipe line clean-out
- Valve body flow area equal to nominal pipe area
- Reinforced steel/ductile iron valve disc
- Lower installation cost
- Optional backflow device
- Optional disc position indicator
- Optional proximity switch model 745PS
- Optional stainless steel bolts

## Model 745 PI

### Optional disc position indicator

Installed by the factory or in the field the disc position indicator provides a visual indication of the disc location during operation or shut down. The 745's top cover is drilled and tapped for installation of the indicator.



## Model 745 BF

### Optional backflow device

The new 745BF swing check provides a drilled and tapped location at the bottom of the valve for installation of a backflow device. Manually operated, this actuator is used when backflow, pump priming, line draining or system tests are required. This option can be factory installed or added in the field.



## Model 745 BFPI

### Optional backflow device & disc position indicator

The new 745BFPI swing check provides both of the above options. Each device can be installed at the time of purchase or added to the valve in the field. A proximity switch is available upon order of the Model 745PS (not pictured).



**Flomatic Valves**

High Quality Valves Built to Last...

[www.flomatic.com](http://www.flomatic.com)

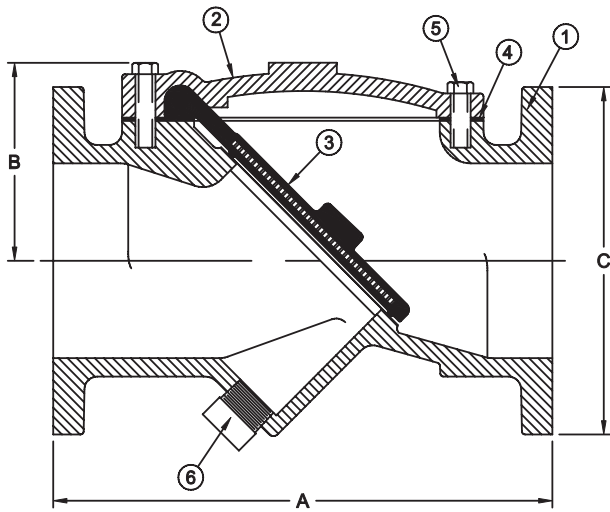

Item #	Qty	Description	Material	ASTM
1	1	Body	Ductile Iron	A536
2	1	Cover	Ductile Iron	A536
3	1	*Disc	Buna coated steel	-----
4	1	Gasket	Rubber	-----
5	A/R	Cover Bolt	Steel	SAE Grade 5
6	1	Plug	Malleable Iron	-----

\*Optional EPDM or Viton Coated Steel

Size Inch	Part #	A Inch	B Inch	C Inch	Weight lbs.
2"	2380	8"	3 3/8"	6"	27
2 1/2"	2381	8 1/2"	3 3/8"	7"	35
3"	2382	9 1/2"	3 7/8"	7 1/2"	40
4"	2383	11 1/2"	4 5/8"	9"	68
5"	2384	13 3/4"	5 1/8"	10"	105
6"	2385	15"	5 7/8"	11"	128
8"	2386	19 1/2"	7 5/8"	13 1/2"	235

Size Inch	Part #	A Inch	B Inch	C Inch	Weight lbs.
10"	2387	24 1/2"	9 7/8"	16"	380
12"	2388	27 1/2"	11 3/8"	19"	620
14"	2390	31"	13 3/8"	21"	740
16"	2391	32"	15 3/8"	23 1/2"	1035
18"	2392	36"	17 1/8"	25"	1540
20"	2393	40"	19 1/8"	27 1/2"	1835
24"	2394	48"	22 3/4"	32"	2475

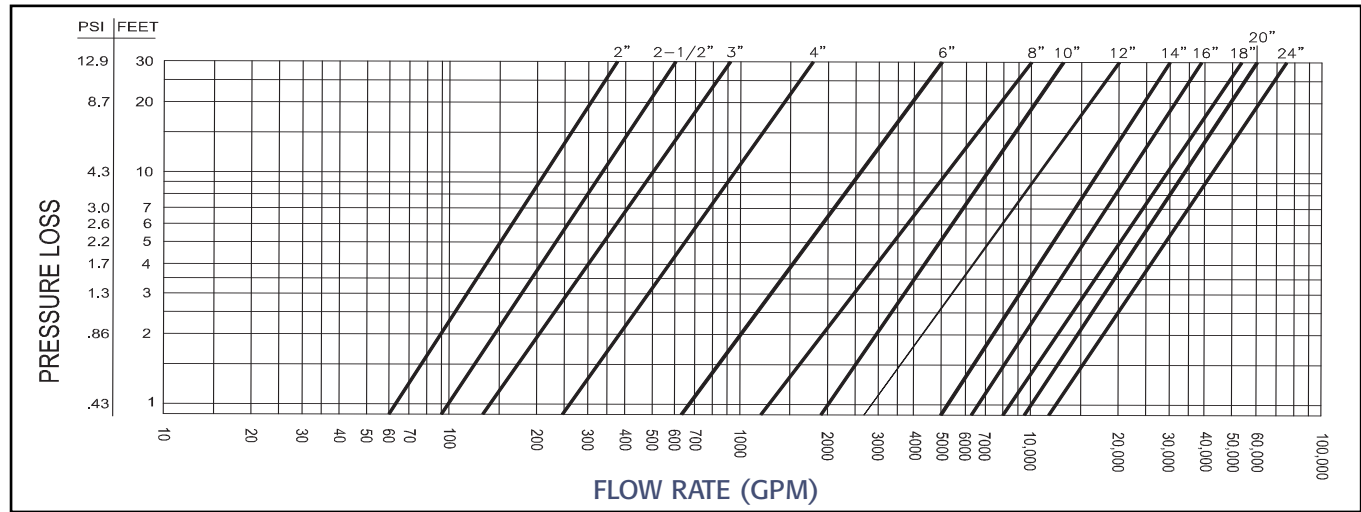

Other Flomatic Valves



**Model 78**

Size range: 1/2" - 14"

Cast iron body. Epoxy coating. Flanged ANSI125 connection. Reinforced rubber swing disc. Inline serviceable.



**Model 78A**

Size range: 3" - 14"

Ductile iron body with epoxy coating. Flanged connection ANSI 125. Reinforced rubber swing disc. In-line serviceable.



**Model 90CS/92CS**

Size range: 2"-30"

Same construction as 90/92. Features external lever and weight and sealed end cushion closure system for adjustable rate of valve closure.



**Model 408**

Size range: 3" - 14"

Cast iron body with epoxy coating and access port, flanged connection ANSI 125. NITRILE (Buna-N) covered metal ball. "Sinking Type".