

## Reduced Pressure Zone Valve

## Installation Instructions



Model RPZ 2-1/2" – 10"



Flomatic Corporation

### Basic Installation Instructions:

**CAUTION: Installation of Backflow Preventers must be performed by qualified, licensed personnel. Faulty installation could result in an improperly functioning assembly.**

The installer should be sure the proper assembly has been selected for the particular installation.

The Flomatic Model RPZ Reduced Pressure Principle Backflow Preventers are for use on potable water lines where a health hazard could exist if a backflow or back-siphonage situation were to occur. Proper performance is dependent upon following these installation instructions and prevailing governmental and industry standards and codes. Failure to do so, according to Flomatic Corporations Limited Warranty "releases Flomatic Corporation of any liability that it might otherwise have with respect to that assembly". Such failure could also result in an improperly functioning assembly.

Damage to the assembly could result wherever water hammer and/or water thermal expansion could create excessive line pressure. Where this could occur, shock arrestors and/or pressure relief valves should be installed downstream of the assembly.

1. Before installing a Model RPZ Backflow Preventer, flush the lines thoroughly to remove all debris, chips and other foreign matter. If required a strainer should be placed upstream of the Backflow Preventer.

**CAUTION: Do not use a strainer in seldom used emergency water lines such as fire lines.**

2. The Model RPZ must be installed in a horizontal or vertical position with flow down to provide proper operation of the relief valve.

3. Provide adequate space around the installed unit so that the test cocks will be accessible for testing and servicing.

4. If installation of a Model RPZ unit is in a building, provide a suitable drain arrangement to drain off spillage from the relief valve. An air gap of at least two times the pipe diameter must be provided between the relief valve and the drain piping to prevent a cross connection.

**CAUTION: Do not pipe the relief valve solidly to a floor drain, sewer or sump.**

5. Install valve at least 12 inches above surrounding flood level.

6. Always consult local codes for installation methods, approvals and guidelines.

### Outdoor Installation

Models RPZ Backflow Preventers may be installed outdoors only if the assembly is protected against any freezing conditions. Exposure to freezing conditions will result in improper function or damage to the assembly. The installation location must be kept above 32<sup>o</sup> F. All the basic installation instructions apply.

If installation is in a pit or vault, the backflow preventer must never be submerged in water because this could cause a cross-connection. Make sure that the pit or vault always remains dry by providing ample drainage.

### Indoor Installation

Indoor installation is preferred in areas that are subject to freezing conditions. All the basic installation instructions apply to such installations.

### Parallel Installation

Where uninterrupted service from a single meter connection must be maintained, two or more Backflow Preventers may be connected in parallel. All the basic installation instructions apply to a parallel installation. Be sure to allow adequate room between the units for testing and repair.

### Placing the Assembly in Service

After the installation of a Model RPZ unit has been completed, place the unit in service as follows:

1. Start with both shut-off valves closed. Slowly open the inlet shut-off valve until the backflow preventer is completely pressurized.
2. A brief discharge from the relief valve may occur while the assembly is pressurizing. The discharge should cease by the time the shut-off valve is fully open.
3. If the discharge does not stop, refer to "Maintenance Instructions" for Repair Procedures.
4. After the assembly has been pressurized, vent all trapped air from both check valves and the relief valve by slightly opening each of the four test cocks.
5. Slowly open the downstream shut off valve. The Model RPZ Reduced Pressure Principle Backflow Preventer is now in service.
6. If 'spitting' or intermittent discharges from the relief valve are noted, 'spitting' (drainage) from the relief valve could be a result of pressure fluctuations and/or water hammer condition in the system. If such condition exists, install water pressure reducing valves or water hammer shock arrestors in compliance with industry standards as needed.
7. After the backflow preventer has been properly installed, test the assembly (see Test Procedures). If the assembly fails the test, remove the first and second check valves and thoroughly flush the assembly. If the relief valve fails to operate properly, inspect the sensing passage for clogging (also see maintenance instructions). Clean rubber seats of all debris and place unit back in service.

### MAINTENANCE INSTRUCTIONS

#### 1. GENERAL

- A. Clean all parts thoroughly with water after disassembly.
- B. Carefully inspect silicone discs, and o-rings for damage.
- C. Test unit after reassembly for proper operation.

#### 2. SERVICING CHECK VALVES

- A. Close inlet and outlet shut-off valves.
- B. Open #2, 3, and 4 test cocks to release pressure from valve.
- C. Remove the cover bolts & valve cover.

#### **CAUTION: COVER IS SPRING LOADED.**

To avoid injury, hold cover down firmly with one hand while loosening bolts.

- D. Remove relief valve cover and assembly.
- E. Remove the check valve spring clips.
- F. Remove the 1st check valve assembly.
- G. Remove the 2nd check valve assembly.
- H. Inspect check valve seat and o-ring for debris and damage.
- I. To remove silicone disc, unscrew check valve stem from disc holder.
- J. Remove disc retainer and disc from the disc holder and inspect for cuts or embedded debris.
- K. The silicone disc may be inverted if the reverse side is undamaged.
- L. Inspect the valve cavity and seat area for damage and debris.
- M. Reverse the above procedures to reinstall the check valve assemblies.

**NOTE: Check valves can only be installed in one configuration, they are not reversible.**

#### 3. SERVICING RELIEF VALVE

- A. Remove relief valve cover bolts.

#### **CAUTION: COVER IS SPRING LOADED.**

Hold cover firmly with one hand while removing bolts.

- B. Remove cover, piston assembly and spring.
- C. Inspect o-ring and diaphragm for cuts or embedded debris.
- D. Remove diaphragm by unscrewing the relief valve piston from the stem.

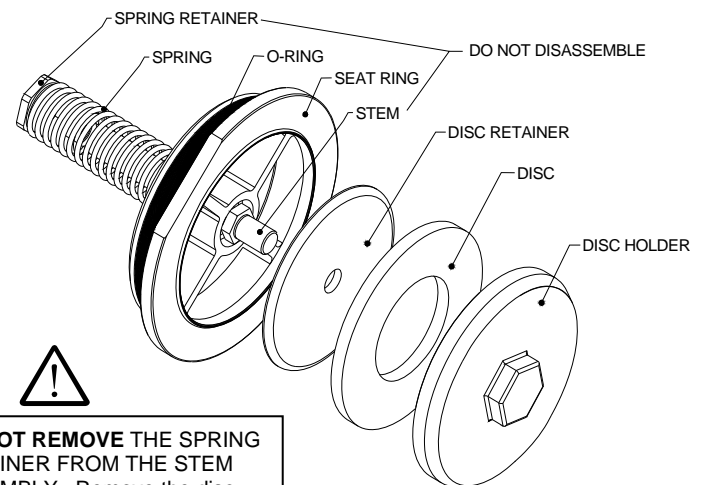

**DO NOT REMOVE THE SPRING RETAINER FROM THE STEM ASSEMBLY. Remove the disc holder from the stem assembly.**

E. Inspect relief valve disc for damage and debris.

F. To remove disc, unscrew disc retainer from relief valve stem.

**NOTE:** Relief valve disc is also reversible.

G. Remove stainless steel relief valve seat and inspect for damage and debris. Also inspect seat o-ring for damage.

H. Reverse the above procedures to reinstall the relief valve.

### TEST PROCEDURES

EQUIPMENT REQUIRED: Differential Pressure Test Gage

**Note: For ALL of the following tests the differential pressure gauge must be held at the same level as the assembly being tested. Be sure that hoses not being used are also kept at this level.**

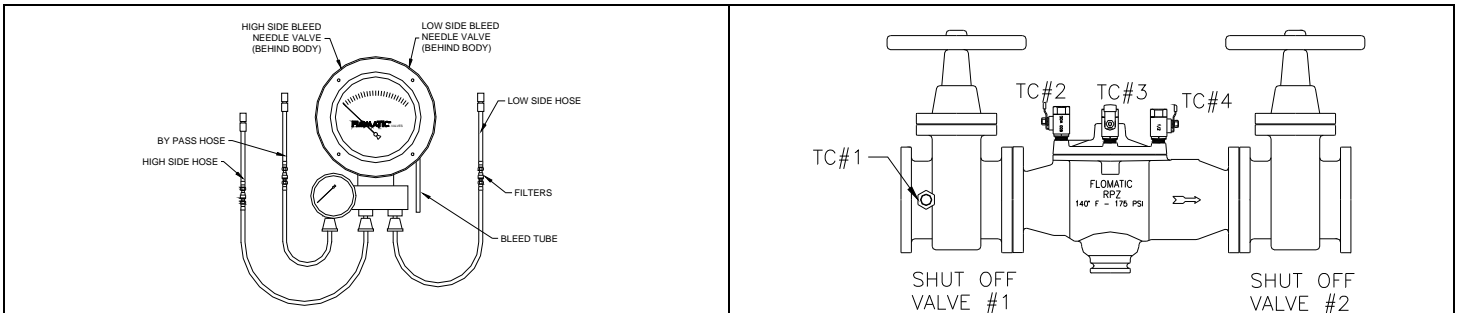

#### TEST #1 - Relief Valve

**PURPOSE:** Test operation of pressure differential relief valve to maintain the zone pressure (between the two check valves) at least 2psi below the supply pressure.

1. Open #4 test cock to establish flow through the unit; then flush water through test cocks #1, #2, & #3, by opening and closing each test cock one at a time, to eliminate foreign material. Be careful not to dump the relief valve during this process (open #2 test cock slowly). Close test cock #4.
2. Install appropriate gauge fittings.
3. Install hose from the high side of the differential pressure gauge to the #2 test cock.
4. Install hose from the low side of the differential pressure gauge to the #3 test cock.
5. Open test cock #3 slowly and bleed all air from the hose and gauge through the low side bleed needle valve. Maintain the low side bleed needle valve in the open position while the test cock #2 is opened slowly. Open the high side bleed needle valve to bleed the hose and gauge. Close the high side bleed needle valve; then close the low side bleed needle valve after the gauge has pinned at the upper end of the scale.
6. Close #2 shut-off valve.
7. Observe the apparent pressure drop across the 1<sup>st</sup> check valve; during all subsequent steps of this procedure the differential gauge is "on line" showing the pressure drop across the 1<sup>st</sup> check valve.
8. Open the high side control needle valve, and then slowly open the low side control needle valve slightly to bypass water from the #2 test cock to the #3 test cock.
9. Watch the pressure differential drop slowly to the relief valve opening point, record this value.
10. Close the needle valves.

#### TEST #2 - 2<sup>nd</sup> Check Valve

**PURPOSE:** Test 2<sup>nd</sup> check valve for tightness against reverse flow.

**REQUIREMENT:** The valve MUST close tight against reverse flow under all pressure differentials.

1. Maintain the No. 2 shut-off valve in a closed position.
2. Vent all of the air through the bypass hose by opening the high side control needle valve and the bypass needle valve. Close the bypass needle valve only.
3. Install the bypass hose from the gauge manifold to the #4 testcock, then open the #4 testcock.
4. Bleed water from the "zone" by opening the low side bleed needle valve on the gauge in order to reestablish the normal reduced pressure within the "zone". Once the gauge reaches the high end of the scale, close the low side bleed needle valve.
5. Open the bypass needle valve. No 2 check valve is "closed tight" if the pressure differential remains steady.

**TEST #3 – 1<sup>ST</sup> Check Valve**

*PURPOSE:* Test pressure drop across the 1<sup>st</sup> check valve.

*REQUIREMENT:* The static differential pressure across check valve #1 must be a minimum of 3psi MORE then the opening differential pressure of the relief valve as recorded in test #1.

1. Hook up bypass hose to testcock #4.
2. Bleed water from the "zone" through the low side bleed needle valve on the gauge until the gauge reaches the high end of the scale. Close the low side bleed needle valve. After the needle settles record the static pressure drop across check valve #1.

**TROUBLE SHOOTING GUIDE**

Symptom	Cause	Solution
1. Valve releases water on and off from the relief valve.	a. Inlet pressure fluctuations  b. Outlet pressure fluctuations.	a. Install a soft seated, spring loaded check valve on the inlet side of the assembly. (Flomatic model 80E)  b. Install a soft seated, spring loaded check valve on the outlet side of the assembly as close as possible to the shutoff valve.
2. Valve releases water constantly from the relief valve.	a. Dirt or debris is on the 1 <sup>st</sup> check.  b. Damaged or dirty relief valve seat.  c. Relief valve piston o-ring not free to move due to scale, dirt or build-up of mineral deposits.  d. Excessive backpressure, freezing or water hammer has distorted the 2 <sup>nd</sup> check.  e. Valve improperly reassembled.	a. Flush valve. If flushing does not work then clean or replace the 1 <sup>st</sup> check.  b. Clean or replace the relief valve seat.  c. Clean, grease or replace the piston o-ring.  d. Eliminate sources of excessive backpressure or water hammer in the system downstream of the assembly. Use Flomatic model 80E to dampen out backpressure. In case of freezing; thaw, disassemble and inspect internal components. Replace as necessary.  e. Install check springs in their proper location.
3. Valve exhibits high pressure drop.	a. Fouled Strainer.  b. Valve too small for flow.	a. Clean strainer or replace.  b. Install proper size assembly
4. No water flows downstream of valve.	a. Valve installed backwards.	a. Install valve in accordance with flow direction arrow.
5. Valve does not test properly.	a. Follow Flomatic's test procedure.  b. Leaky downstream gate valves.	a. & b. Clean or replace gate valves with full ports ball valves or resilient wedge shutoff valves.
6. Valve quickly and repeatedly fouls following servicing.	a. Debris in pipeline is too fine to be trapped by strainer.	a. Install a finer mesh strainer element in the strainer.

**3 Year Limited Warranty:** Flomatic valves are guaranteed against defects of materials or workmanship when used for the services recommended. If in any recommended service, a defect develops due to material or workmanship, and the assembly is returned, freight prepaid, to Flomatic Corporation within 36 months from the date of purchase, it will be repaired or replaced free of charge. Flomatic Corporations' liability shall be limited to our agreement to repair or replace the valve only.