



NOTE: Submersible motor manufacturers recommend using a flow inducer sleeve to be sure the motor is properly cooled at low flows. Do not exceed 125 psi pressure differential across the valve.

NOTICE: Annual inspection and maintenance is required of all plumbing system components. To ensure proper performance and maximum life, this product must be subject to regular inspection, testing and cleaning.

Regulators in series: Where the desired pressure reduction is more than a 4 to 1 ratio (i.e.. 200psi to 50psi), multiple regulators in series should be installed.

DIAPHRAGM WARNING: Loosen adjustment screw slowly. Look for any trapped water pressure under the diaphragm. Relieve pressure before removing cover.

CAUTION: Anytime a reducing valve is adjusted, a pressure gauge must be used downstream to verify correct pressure setting. To properly adjust the downstream pressure there needs to be flow through the valve in the direction of the flow arrow on the body. Do not bottom out adjustment screw on cover. Valve may be installed in any position.

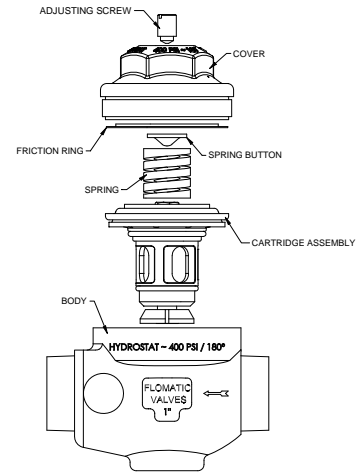

INSTALLATION INSTRUCTIONS:

1. Before installing reducing valve, flush out line to remove loose dirt and scale which might damage disc and seat and turn power off. Install valve in line with arrow on valve body pointing in direction of flow.

2. Install the valve downstream of the pump and before the pressure switch and tank. **Note: If there are any water outlets such as yard hydrant or supply between the pump and Hydrostat® install a by-pass with a check valve around the valve. The check valve shall be installed with flow going in the opposite direction of the Hydrostat®. This allows for free flow around the Hydrostat® unit to provide tank pressure to the yard hydrant or outlet (see illustration).**

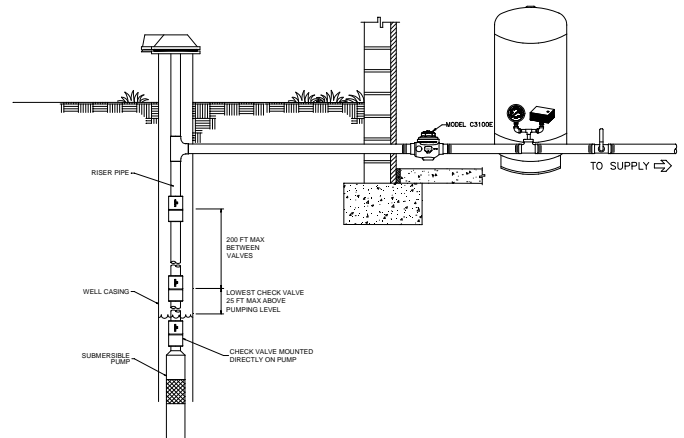

3. Pre-charge pressure in the tank should be 5 to 10 PSI lower than pressure switch turn "ON" pressure. All valves are factory pre set to 60 PSI. At this standard pressure regulation the pressure switch shall normally be set for "ON" at 60 PSI and "OFF" at 70 PSI. To re-adjust reduced pressure turn adjustment screw clockwise (into cover) to increase downstream pressure, or turn counterclockwise (out of cover) to lower downstream pressure. Valve may be installed in the horizontal or vertical position. Open a line downstream and allow the pump to turn on, then slowly close supply valve downstream until demand is roughly around 2 to 3 GPM. Then adjust the valve until the downstream pressure is constant, at about 10 PSI lower than the cut off pressure of the pressure switch setting. Close off downstream valve and the pressure tank will fill up at about 1 GPM. (1-1/8" – 1-1/4" turns on adjusting screw is approximately 10psi).

***Note:** In systems using a small tank with 5 gallons or less of drawdown, adjust the regulated downstream valve pressure to the same as the cut in (pump on) pressure setting of the pressure switch. For example if your system is using a 40/60 pressure switch setting set your regulated downstream valve pressure at 40 PSI. For longer run times set your regulated pressure closer to the cut "ON" (pump on) pressure switch setting.

General Trouble Shooting

Pipe lines in a water supply system must be of sufficient carrying capacity to maintain adequate pressure at the most remote or highest fixture. Under the maximum probable fixture use, minimum adequate pressure is generally 8 to 15 lbs., but may be more, depending on the equipment being supplied.

Relatively high service pressures which can create high water velocities in pipe lines would allow use of smaller pipes to satisfy fixture use. However, high velocities tend to cause whistling and humming. Reductions of pressure by the use of a pressure reducing valve, in an attempt to eliminate the undesirable condition, may reduce pipe line capacities below what is adequate for maximum probable use.

When high service pressures are in effect, either continuously or periodically, the application of a pressure reducing valve will be successful only when the installed pipe line is of adequate size to satisfy the system demand at the lower pressure. When actual water demands are unknown, the valve size should be no less than the existing pipe size.

<p style="text-align: center;">PROBLEM</p> <p style="text-align: center;">1. Pressure and fixture flow unsteady.</p>	<p style="text-align: center;">POSSIBLE CAUSE OR CAUSES</p> <p>A. Low water supply pressure in main supply line caused possibly by inadequate pump pressure. B. Heavy periodic demands by appliances in the house.</p>
<p>SOLUTION:</p> <p>A. Pump may need to be serviced. B. Alternate appliance usage to reduce over usage. C. Increase pressure. D. House service lines may at times be inadequate for the load. Size of some pipes may need to be increased.</p>	
<p style="text-align: center;">PROBLEM</p> <p style="text-align: center;">2. Pump continues to cycle on and off</p>	<p style="text-align: center;">POSSIBLE CAUSE OR CAUSES</p> <p>A. Pressure switch may not be set correctly. B. Valve regulated pressure is set to close to the shut off pressure of the pressure switch. C. Sealing disc in valve is wore or damaged. D. Damaged or torn diaphragm in valve. E. Water tank has become waterlogged.</p>
<p>SOLUTION:</p> <p>A. Readjust pressure switch setting higher than the regulated set pressure. B. Readjust the regulated pressure setting on the valve to the cut in pressure of the pressure switch setting. For example 40/60 switch set the valve at 40 psi C. Replace sealing disc in valve. D. Replace diaphragm in valve. E. Recharge tank or replace.</p>	
<p style="text-align: center;">PROBLEM</p> <p style="text-align: center;">3. Valve appear to be noisy, hums, whistles or chatters</p>	<p style="text-align: center;">POSSIBLE CAUSE OR CAUSES</p> <p>A. High velocity of flow in pipelines causing vibration due to excessive pressure drop across valve. B. Chatter usually originates with worn small washer or loosely installed disc. C. Air pressure in tank is set too high.</p>
<p>SOLUTION:</p> <p>A. Use a second valve to reduce the differential pressure to the original valve. B. Replace the small washer and sealing disc. C. Reset the air pressure in the tank to 6-10 psi below the cut in (pump on) pressure setting on the pressure switch.</p>	

Limited Three Year Warranty: Flomatic Regulators are guaranteed against defects of material or workmanship when used for the services recommended. If, in any recommended service a defect develops due to material or workmanship, and the regulator is returned, freight prepaid, to us within 36 months from date of shipment from our factory, it will be repaired or replaced free of charge. Flomatic Corporations liability shall be limited to our agreement to repair or replacement of regulator only. The Flomatic regulator described in this Bulletin is suitable for water service only.