

FAILURE TO FOLLOW THESE INSTRUCTION WILL VOID ANY WARRANTY

CAUTION: Installation of model 745 must be performed by qualified, licensed personnel. Faulty installation could result in an improperly functioning device.

Proper performance depends upon following these installation instructions and prevailing governmental and industry standards and codes. Failure to do so release's Flomatic Corporation of any liability that it might otherwise have with respect to that device. **NOTICE:** Annual inspection and maintenance is required of all plumbing system components. To ensure proper performance and maximum life, this product must be subject to regular inspection, testing, adjustment and cleaning.

1. Remove line pressure and drain valve.
2. Remove pipe plug from cover.
3. Install Mounting Nut (10), with Teflon tape into cover.
IMPORTANT: The mounting nut must be oriented with wrench flats parallel to pipeline and with angled threaded hole perpendicular to swing check valve flapper. This is required to insure proper orientation of position indicator assembly to flapper for correct operation.
4. Install assembled position indicator with Teflon tape in mounting nut by inserting the shaft end with ball through the threaded hole in mounting nut and tighten.
5. Adjust position indicator using the following sequence:
 - a) Remove Sight Housing (1) from Sight Base (6). Hold sight base with a wrench to avoid removing it from Indicator Nut (7).
 - b) Remove Spring (2).
 - c) Loosen Nut (3) and back off.
 - d) Back off Spring Seat (4).
 - e) The position of Sight Base (6) controls compression of the Packing (9). Initially there should be approximately a 3/8" gap between the Sight Base (6) and Indicator Nut (7).
 - f) Insure that the check valve flapper is in the fully closed position and manually push Indicator Rod (13) down until Contact Ball (14) firmly contacts check valve flapper.
 - g) Adjust Spring Seat (4) to a position approximately in the middle of threaded section of Indicator Rod (13).
 - h) **NOTE:** spring seat should not contact the top of the sight base as this will limit travel in the closed direction.
 - i) Tighten Nut (3) against Spring Seat (4) to lock in position.
 - j) Reinstall Spring (2).
 - k) Reinstall Sight Housing (1) onto Sight Base (6). Hold sight base with a wrench to avoid turning it into Indicator Nut (7) and changing the packing compression.
6. Verify function of position indicator by manually opening the check valve flapper. The indicator rod and contact should move up in the assembly and must return with the check valve flapper when released. If the indicator rod and contact ball do not return and make contact with the check valve flapper, the Spring Seat (4) should be adjusted up to increase spring compression.

NOTE: Packing compression adjustment affects operation of the indicator rod. It may be necessary to readjust the spring tension after initial operation and adjustment of the packing, as the assembly will move more freely once the packing glands are seated.

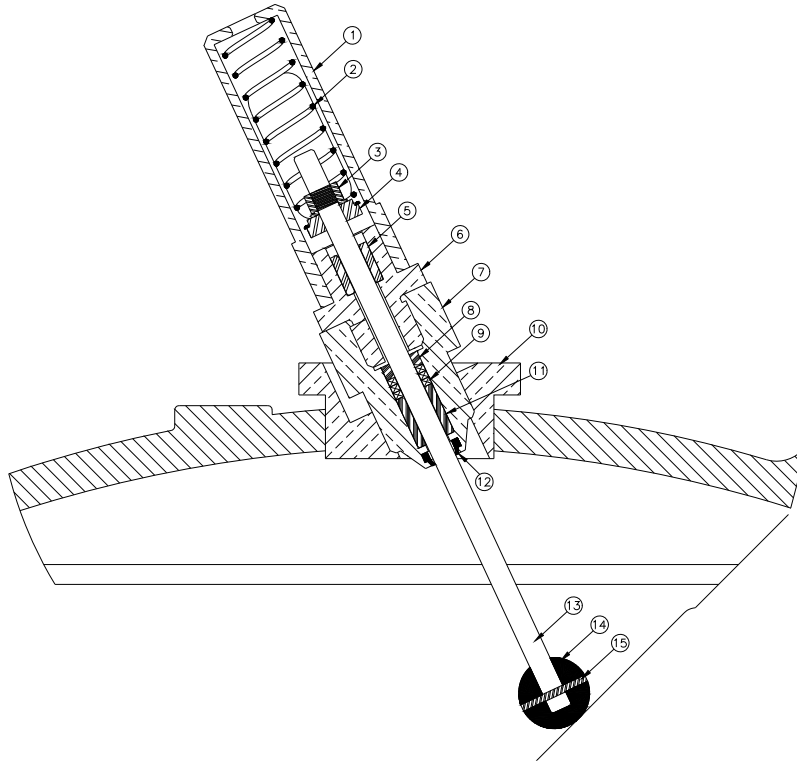

Item	Description
1	Sight Housing
2	Spring
3	Nut/Washer
4	Spring Seat
5	Top Bushing
6	Sight Base
7	Indicator Nut
8	Gland Bushing
9	Packing
10	Mounting Nut
11	Bottom Bushing
12	Rod Washer
13	Rod
14	Contact Ball
15	Pin

1 Year Limited Warranty: Flomatic valves are guaranteed against defects of materials or workmanship when used for the services recommended. If in any recommended service, a defect develops due to material or workmanship, and the device is returned, freight prepaid, to Flomatic Corporation within 12 months from the date of purchase, it will be repaired or replaced free of charge. Flomatic Corporations' liability shall be limited to our agreement to repair or replace the valve only.