

FAILURE TO FOLLOW THESE INSTRUCTION WILL VOID ANY WARRANTY

Connect the supply piping to the bottom of the Flomatic Valves model AVB. Connect the outlet of the vacuum breaker to the fixture being served as shown in the diagram below.

The extreme bottom of the AVB shall be taken as the critical installation level. Therefore, the highest fixture being served shall be a minimum of 6 inches (150mm) below the bottom of the AVB.

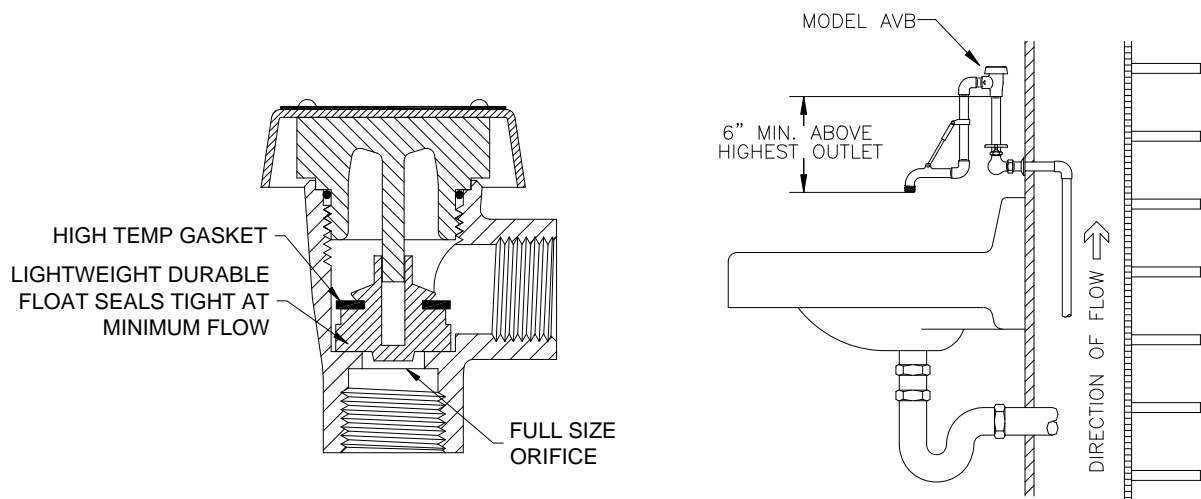

ATMOSPHERIC VACUUM BREAKER
INDOOR INSTALLATION

CAUTION: This device should never be used in installations that are under continuous pressure. Therefore, never place a shut-off or check valve downstream of AVB's.

This device shall not be installed in a concealed or inaccessible location, or where the venting water from the device during normal functioning may be deemed objectionable.

1 Year Limited Warranty: Flomatic valves are guaranteed against defects of materials or workmanship when used for the services recommended. If in any recommended service, a defect develops due to material or workmanship, and the device is returned, freight prepaid, to Flomatic Corporation within 12 months from the date of purchase, it will be repaired or replaced free of charge. Flomatic Corporations' liability shall be limited to our agreement to repair or replace the valve only.