

Description:

The FC20 Flow Control Valve is an all stainless steel spring-loaded needle type check valve. The flow rate is unrestricted flow in one direction and restricted or metered flow in the other. The flow rate is only adjustable in the restricted direction. It is to be used with automatic control valve pilot control systems.

Operation:

The FC20 Flow Control Valve permits full flow in the direction of the body marking arrow and restricted flow in the reverse direction. Flow from inlet to outlet lifts the seat disc off of the seat thus allowing full flow. Flow in the opposite direction causes the seat disc to seal, allowing fluid to pass thru the adjustable opening between the needle and seat disc. Adjusting the needle counterclockwise increases the opening between the needle and the seat allowing more flow. Adjusting the needle clockwise decreases the opening between the needle and the seat reducing flow.

Installation:

Installation must be performed by qualified, licensed personnel only.

The FC20 Flow Control Valve should be installed as shown in the piping schematic that came with your control valve. Make sure all connections are tight to prevent leakage or damage to your valve.

Adjustment Procedure:

Loosen the adjustment needle jamb nut. Turning the needle out (counter-clockwise) increases the opening between the needle and the seat disc, which increases the flow. Turning the needle in (clockwise) reduces the opening between the needle and the seat disc, which reduces the flow. After adjustment is complete retighten the adjustment needle jamb nut.

MAINTENANCE & REPAIR

Annual inspection and maintenance is required of all plumbing system components. To ensure proper performance and maximum life, the FC20 must be inspected, tested and cleaned on a regular basis. Disassemble the valve according to the exploded diagram. Inspect all threads for signs of damage or cross-threading. Make sure the seat disc and seat of valve body do not show wear, damage or foreign material which can stop the valve from opening or seating correctly. The spring should be checked for cracks, damage or distortion. The adjustment needle should be free from nicks or burs which can stop the valve from opening. Inspect all parts for damage, wear and corrosion. Replace all damaged components and items that appear would keep the valve from functioning correctly. The o-ring and cover seal should be replaced whenever the FC20 is serviced. Make sure to clean all parts before you reassemble the valve. Re-assemble the valve according to the cross sectional view.

TEST PROCEDURE

The FC20 Speed Control Valve does not require testing before being re-installed.

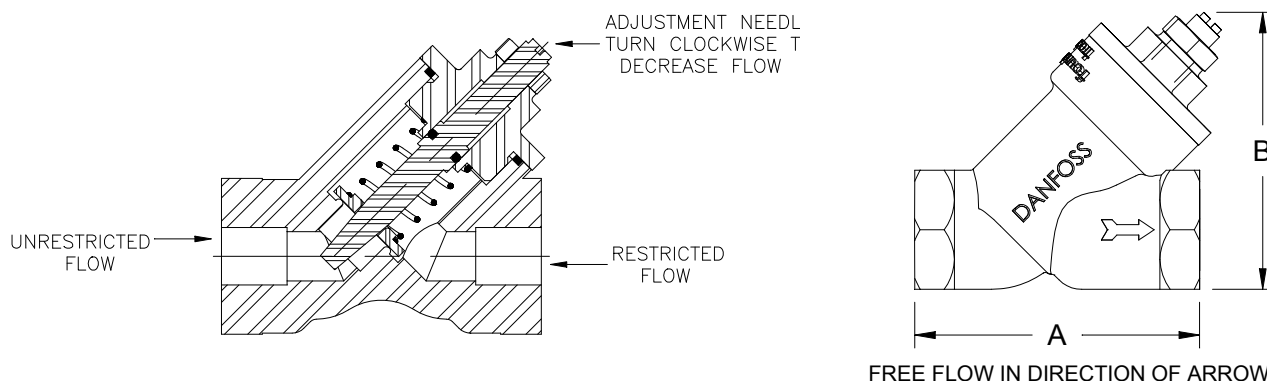

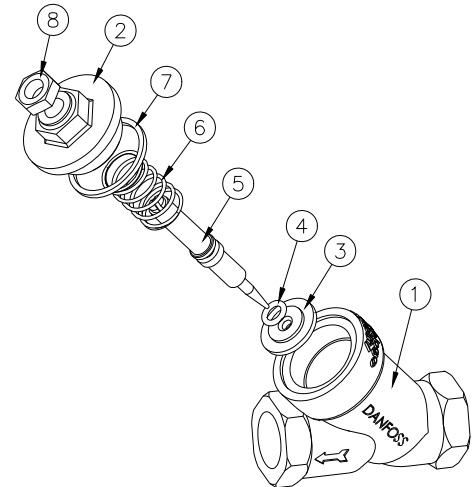
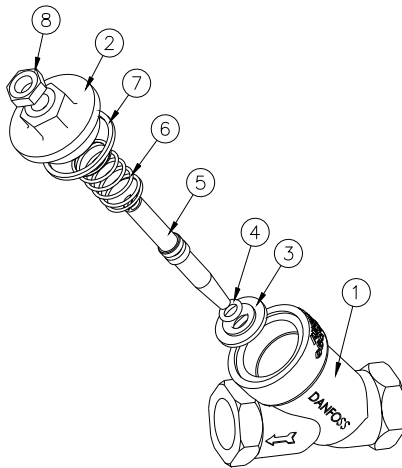

Size		Part #	A		B		Weight	
inch	mm		inch	mm	inch	mm	lbs	kg
1/4	8	FC20-001-01	2.20	56	2.15	55	1	.454
3/8	10	FC20-002-01	2.20	56	2.15	55	1	.454

Size		Part #	A		B		Weight	
inch	mm		inch	mm	inch	mm	lbs	kg
1/4	8	FC20-201-01	2.20	56	2.15	55	1	.454
3/8	10	FC20-202-01	2.20	56	2.15	55	1	.454

Item #	Qty	Description	Material	ASTM
1	1	Body (W/ Tag & Plug)	Stainless Steel	316
2	1	Cap	Stainless Steel	316
3	1	Seat Disc	Stainless Steel	316
4	1	O-Ring	Buna-n	-----
5	1	Needle	Stainless Steel	316
6	1	Spring	Stainless Steel	316
7	1	Cover Seal	Teflon	-----
8	1	Adjusting Nut	Stainless Steel	316

Information needed to order repair parts:

Speed Controller Size

Limited One Year Warranty: Flomatic valves are guaranteed against defects of material or workmanship when used for the services recommended. If, in any recommended service a defect develops due to material or workmanship, and the device is returned, freight prepaid, to Flomatic Corporation within 12 months from date of purchase, it will be repaired or replaced free of charge. Flomatic Corporation's liability shall be limited to our agreement to repair or replacement of valve only.