

**SHIPMENT & STORAGE:**

- Prior to installation verify:
  - That the 109 NRS gate valve selected is correct for the application.
  - That the valve is free of shipping damage.
  - That all sealing surfaces are clean and free from debris.
  - That all scale, debris, foreign materials are removed from piping system.
  - That valve operator is properly secured to valve.
  - If water is allowed to freeze in the valve severe damage may occur.

**Standards / Ratings:**

Nominal Diameters	2-1/2" (65mm) THRU 12" (300mm)
Max Working Temperature	140° F (60° C)
Max Pressure	250 psi (17 bar)
Flanges Rating	ANSI 150 (B16.42)
Opening	Left Turn (Optional Right Turn)*

\*Consult factory for lead time

- The product complies with the requirements of AWWA C509.
- FDA compliant (inside and out)

**OPTIONAL OPERATED METHODS:**

- Hand wheel standard
- Operating Nut is optional

**INSTALLATION:**

- Check to make sure the 109 NRS gate valve flanges are clean and again that there is no damage to valves. It is recommended that you open and close the valve to insure there is not damage.
- Close the wedge before installing the 109 NRS gate valve.
- Make sure the hand wheel is properly secured to the valve stem.
- Place the 109 NRS gate valve in position.
  - Do NOT drop into position.
  - Do NOT hold by the hand wheel.
  - Do NOT strap through the valve opening.
- The 109 NRS gate valve should be properly support to avoid stress on it.
- A valve box / vault must be provided for valves used in buried service. No load should be transferred to the valve by the box/vault.
- Once the 109 NRS gate valve is installed, make sure to check all bolts have the correct torque on them.
- Buried valves must be pressurized and checked for leaks before backfilling.
- Open the valve fully and flush the entire system. Debris can stop the valve from closing all the way and damage the wedge.
- During operation:
  - Do not use 109 NRS gate valve in systems that exceed the rated working pressures.
  - The system must be completely flushed before the 109 NRS gate valve is operated in a normal cycle.
  - If the 109 NRS gate valve fails to seal after the necessary number of turns, open and close the valve several times and reseal.
- Recommended routine inspection checks should include:
  - Verification by visual inspection that all the gaskets and joints are free from leakage.
  - Verification that the valve operator is in working condition.
  - Verify that valve is opening and closing smoothly in a pressurized line.
  - Verify that valve is leak tight in closed position.

**High Quality Valves Built to Last...**
 Flomatic Corp, 15 Pruyn's Island, Glens Falls, New York 12801  
 Phone: 518-761-9797 Fax: 518-761-9798 www.flomatic.com

**REMOVING VALVE FROM SYSTEM:**

• **WARNING!**



Loosening the bolts on a pressurized valve/system can cause the valve to shift and release uncontrolled pipeline fluid. This will cause personal injury and/or pipeline damage.

- Relieve the pressure from the system and make sure to drain the pipeline before loosening valve bolting.
- Close the 109 NRS gate valve before removing from between the pipe flanges.



If the 109 NRS gate valve has an electric actuator make sure to turn off and lock out the power before removing or servicing.

- Support the 109 NRS gate valve, remove the bolts completely then remove the 109 NRS gate valve from the pipeline.



Do not lift by the operator or stem – this will damage the 109 NRS gate valve and void the warranty.

**DISSASSEMBLY:**

- Remove the HHCS and washer
- Remove the hand wheel
- Remove the nuts and washers holding on the bonnet
- Remove the bonnet and slide HHCS out of the cover
- Remove the bolts, washer and nuts from the cover that hold it to the body
- Carefully remove the cover and stem assembly from the body
- Spin the wedge and wedge nut off the stem
- Remove the stem gasket
- Then pull the stem through the cover, being careful not to lose the thrust washers

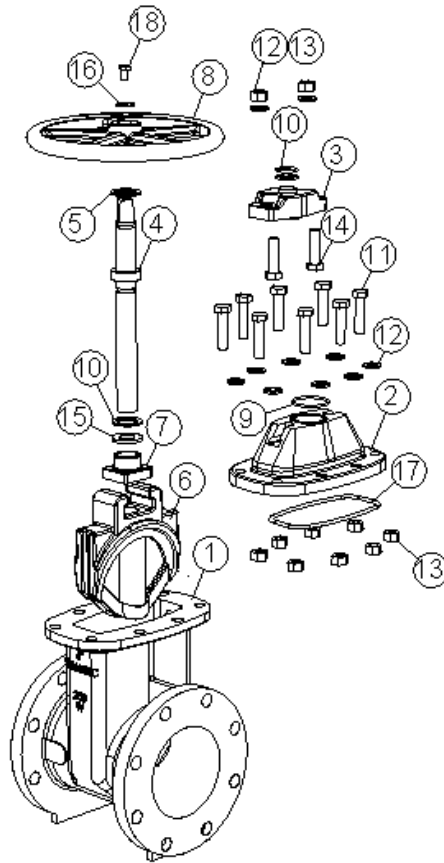

ITEM NO.	QTY.	DESCRIPTION
1	1	BODY
2	1	COVER
3	1	BONNET
4	1	STEM
5	2	THRUST WASHER
6	1	WEDGE
7	1	WEDGE NUT
8	1	HANDWHEEL
9	1	O-RING, BONNET
10	2	O-RING, STEM
11	8	HEX HEAD CAP SCREW (HHCS)
12	10	WASHER
13	10	HEX NUT
14	2	HEX HEAD CAP SCREW
15	1	STEM GASKET
16	1	WASHER
17	1	O-RING, COVER
18	1	HEX HEAD CAP SCREW (HHCS)

**High Quality Valves Built to Last...**

Flomatic Corp, 15 Pruyn's Island, Glens Falls, New York 12801  
Phone: 518-761-9797 Fax: 518-761-9798 www.flomatic.com

**TROUBLE SHOOTING:**

PROBLEM	REASON	POSSIBLE SOLUTION
Valve does not fully close	Debris wedged between wedge and valve body	Open valve to flush out debris
Leakage at sealing surface	Wedge damaged or dirty	Clean and or Replace wedge, clean the sealing surface
Leakage past stem	Bolts loose, or O-rings damaged	Tighten bolts or replace O-rings
Leakage at flange end	The bolt did not contact tightly, or not uniform, or gasket damaged	Tighten bolts or replace gasket



**Warning: Working pressure, temperature, media must match valve capability or valve/piping damage can occur.**

- Working pressure must not exceed valve maximum pressure rating.
- Temperature must not exceed maximum temperature rating.
- Media must be compatible with body, seat, seals and disc material.

***Flomatic Valves is not responsible for the loss caused by the usage beyond the valve capabilities.***

**Opening and Bolt Information:**

SIZE		Flange 125#				
in	mm	QTY	Bolt Ø	Bolt Length	Torque (ft/lbs)	Min # Turns to Open
2-1/2	65	4	5/8	2-1/2	25-75	5
3	80	4	5/8	2-1/2	25-75	9
4	100	8	5/8	3	30-90	12
6	150	8	3/4	3-1/4	30-90	18
8	200	8	3/4	3-1/2	40-120	24
10	250	12	7/8	3-3/4	45-150	30
12	300	12	7/8	3-3/4	65-200	36

NOTES:

**Limited One Year Warranty:** Flomatic valves are guaranteed against defects of material or workmanship when used for the services recommended. If, in any recommended service a defect develops due to material or workmanship, and the device is returned, freight prepaid, to Flomatic Corporation within 12 months from date of purchase, it will be repaired or replaced free of charge. Flomatic Corporations' liability shall be limited to our agreement to repair or replacement of valve only. © 2022

***High Quality Valves Built to Last...***

Flomatic Corp, 15 Pruyn's Island, Glens Falls, New York 12801  
Phone: 518-761-9797 Fax: 518-761-9798 www.flomatic.com