

# Swing Check Valve 125# Flange Model 92LW



Sizes 4" & 6" / 100 mm & 150 mm

Flomatic Corporation

## Materials (Lever & Weight)

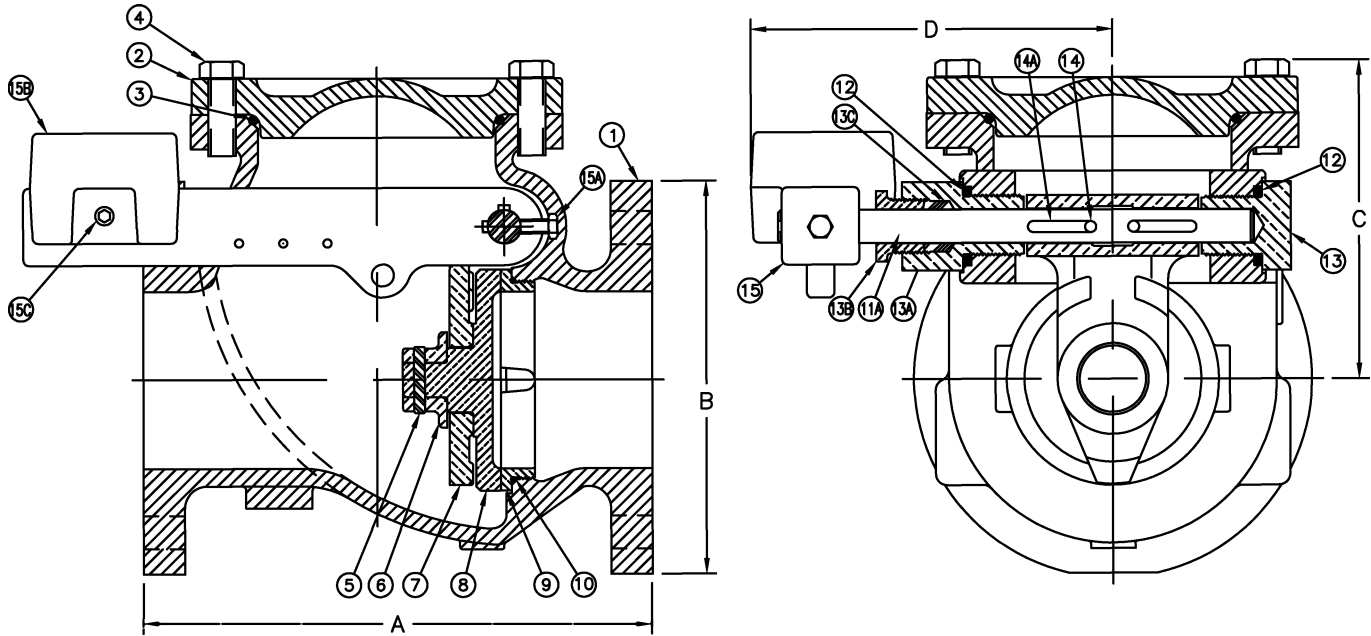

Item #	Qty	Description	Material	ASTM	Item #	Qty	Description	Material	ASTM
1	1	Body*	Cast Iron	A126	12	2	Bearing O'Ring	Buna-n	—
2	1	Cover*	Cast Iron	A126	13	1	Shaft Support Bearing	Bronze	B140
3	1	Cover O'Ring	Buna-n	—	13A	1	Open End Support Shaft Bearing	Bronze	B140
4	4	Cover Bolt	Stainless Steel	18-8	13B	1	Shaft Packing Nut	Bronze	B140
5	1	Flapper End Cap Pin	Stainless Steel	18-8	13C	4	Teflon Packing	Teflon	—
6	1	Flapper End Cap	Federalloy	I-836-FL	14	1	Screw	Stainless Steel	18-8
7	1	Hinge Lever Arm	Federalloy	I-836-FL	14A	3	Key Stock	Stainless Steel	18-8
8	1	Flapper Plate	Federalloy	I-836-FL	15	1	Lever Arm*	Ductile Iron	65-45-12
9	1	Seat Ring	Federalloy	I-836-FL	15A	1	Bolt	Stainless Steel	18-8
10	1	Seat Ring O'Ring	Buna-n	—	15B	1	Weight*	Cast Iron	A126
11A	1	Flapper Support Shaft	Stainless Steel	17-4	15C	1	Bolt	Stainless Steel	18-8

\*Epoxy Coated  
Optional resilient seat (Nitrile) available, add "R" to end of part number

MANUFACTURED IN  
COMPLIANCE WITH  
AWWA C508 STANDARD

## Dimensions

Size		Part #	A		B		C		D		Weight	
inch	mm		inch	mm	inch	mm	inch	mm	inch	mm	lbs	kg
4	100	3707LW	11-1/2	292	8-57/64	226	7-7/32	183	8-3/16	208	125	57
6	150	3709LW	14	356	10-3/4	273	8-17/32	217	9-7/32	234	224	102

Flomatic Corporation can accept no responsibility for possible errors in catalogues, brochures and other printed material. Flomatic Corporation reserves the right to alter its products without notices. This also applies to product already agreed. All trademarks in this material are property of the respective companies. All right reserved. ©2011 Flomatic Corporation. The drawings & information on this drawing sheet are the sole & exclusive property of Flomatic Corporation. Any reproduction, distribution, display or use of these drawings or information in whole or in part without written authorization of Flomatic Corporation is strictly prohibited.

FLOMATIC CORPORATION  
GLENS FALLS, N.Y. 12801  
PHONE (518) 761-9797  
FAX (518) 761-9798

November 19, 2004  
Dwg No: S3707LW Rev A (5/11)



INSTALATION OPERATION & MAINTENANCE INSTRUCTION FOR  
FLOMATIC SERIES  
4" & 6" 92, 92LW, 92LS SWING CHECK VALVES

INSTALLTION INSTRUCTIONS:

1. INSURE ALL SHIPPING WEDGES ARE REMOVED FROM GATE ASSEMBLY.
2. CHECK VALVE FOR OPERATION BY LIFTING LEVER ARM OR GATE ASSEMBLY.
3. INSTALL CHECK VALVE WITH FLOW ARROW IN DIRECTION OF FLOW.
4. VALVE MAY BE INSTALLED VERTICALLY OR HORIZONTALLY.

INSPECTION DISASSEMBLY:

1. ISOLATE VALVE FROM SYSTEM PRESSURE BY CLOSING UPSTREAM AND DOWNSTREAM SHUT-OFF VALVES.
2. REMOVE COVER BOLTS.
3. REMOVE COVER AND O-RING.
4. LIFT GATE ASSEMBLY AND INSPECT VALVE SEAT RING AND GATE ASSEMBLY FOR DAMAGE. REPLACE PARTS IF NECESSARY.

VALVE REASSEMBLY:

1. AFTER REPLACEMENT OR INSPECTION OF INTERNAL COMPONENTS, REASSEMBLE VALVE IN REVERSE ORDER OF DISASSEMBLY INSTRUCTIONS.
2. IF VALVE LEAKS AROUND SHAFT PACKING, TURN PACKING NUT CLOCKWISE UNTIL LEAKING HALTS.

RECOMMENDED SPARE PARTS FOR  
FLOMATIC 4" & 6" SERIES 92, 92LW, 92LS

<u>DESCRIPTION</u>	<u>QUANTITY</u>
DISC	1
SEAT RING	1
PACKING	1
SHAFT KEY	3
COVER O-RING	1
SHAFT (BEARING) O-RING	2
SEAT RING O-RING	1

MANUFACTURED IN  
COMPLIANCE WITH  
AWWA C508 STANDARD

Flomatic Corporation can accept no responsibility for possible errors in catalogues, brochures and other printed material. Flomatic Corporation reserves the right to alter its products without notices. This also applies to product already agreed. All trademarks in this material are property of the respective companies. All right reserved. ©2011 Flomatic Corporation. The drawings & information on this drawing sheet are the sole & exclusive property of Flomatic Corporation. Any reproduction, distribution, display or use of these drawings or information in whole or in part without written authorization of Flomatic Corporation is strictly prohibited.