

# Swing Check Valve 125# Flange

# Model 92 FLOMATIC®

Sizes 4" & 6" / 100 mm & 150 mm

Flomatic Corporation

## Materials

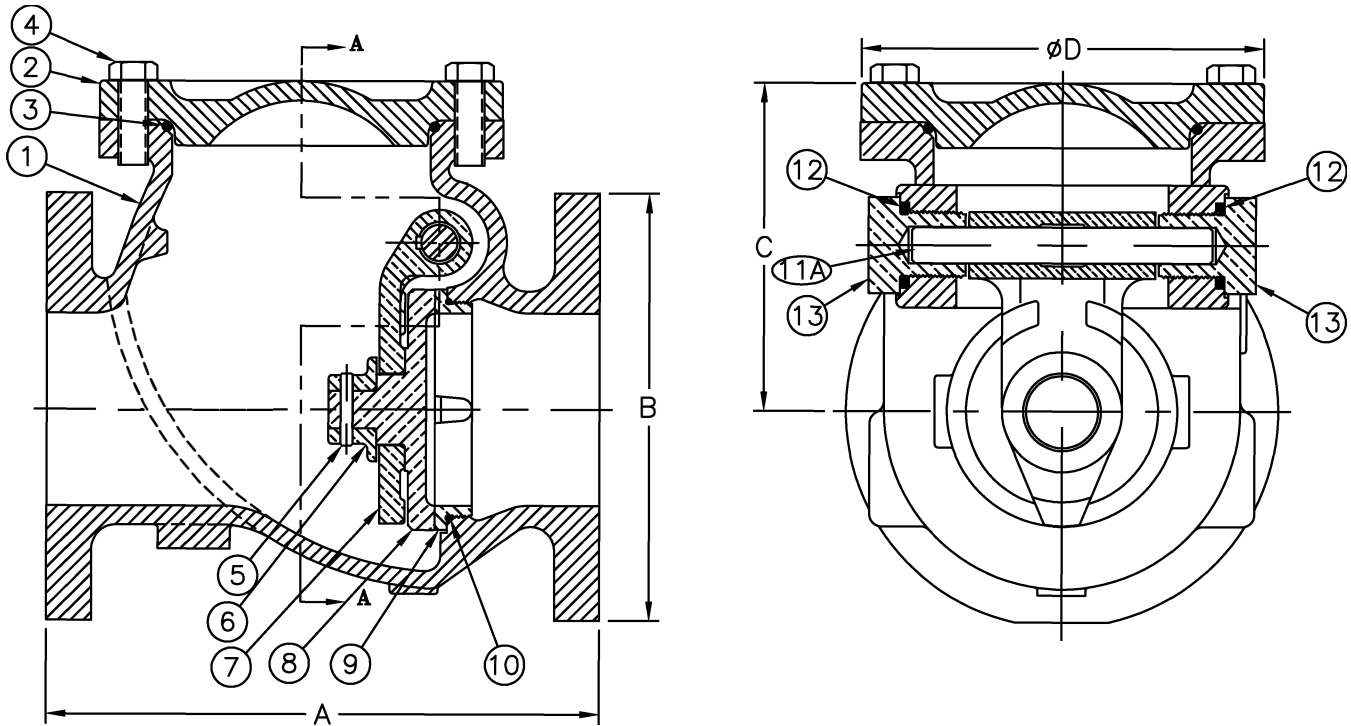

Item #	Qty	Description	Material	ASTM	Item #	Qty	Description	Material	ASTM
1	1	Body*	Cast Iron	A126	8	1	Flapper Plate	Federalloy	I-836-FL
2	1	Cover*	Cast Iron	A126	9	1	Seat Ring	Federalloy	I-836-FL
3	1	Cover O'Ring	Buna-n	—	10	1	Seat Ring O'Ring	Buna-n	—
4	4	Cover Bolt	Stainless Steel	18-8	11A	1	Flapper Support Shaft	Stainless Steel	17-4
5	1	Flapper Bolt	Stainless Steel	18-8	12	2	Bearing O'Ring	Buna-n	—
6	1	Flapper Nut	Federalloy	I-836-FL	13	2	Shaft Support Bearing	Bronze	B140
7	1	Hinge Lever Arm	Federalloy	I-836-FL	*Epoxy Coated Optional resilient seat (Nitrile) available, add "R" to the end of the part number				

## Dimensions

MANUFACTURED IN  
COMPLIANCE WITH  
AWWA C508 STANDARD

Size		Part #	A		B		C		D		Weight	
inch	mm		inch	mm	inch	mm	inch	mm	inch	mm	lbs	kg
4	100	3707	11-1/2	292	8-57/64	226	7-7/32	183	8-3/8	213	109	50
6	150	3709	14	356	10-3/4	273	8-17/32	217	10-7/16	265	195	89

Flomatic Corporation can accept no responsibility for possible errors in catalogues, brochures and other printed material. Flomatic Corporation reserves the right to alter its products without notices. This also applies to product already agreed. All trademarks in this material are property of the respective companies. All right reserved. ©2011 Flomatic Corporation. The drawings & information on this drawing sheet are the sole & exclusive property of Flomatic Corporation. Any reproduction, distribution, display or use of these drawings or information in whole or in part without written authorization of Flomatic Corporation is strictly prohibited.

FLOMATIC CORPORATION  
GLENS FALLS, N.Y. 12801  
PHONE (518) 761-9797  
FAX (518) 761-9798

November 19, 2004  
Dwg No: S3707 Rev A (5/11)

# FLOMATIC®

INSTALLATION OPERATION & MAINTENANCE INSTRUCTION FOR  
 FLOMATIC SERIES  
 4" & 6" 92, 92LW, 92LS SWING CHECK VALVES

INSTALLTION INSTRUCTIONS:

1. INSURE ALL SHIPPING WEDGES ARE REMOVED FROM GATE ASSEMBLY.
2. CHECK VALVE FOR OPERATION BY LIFTING LEVER ARM OR GATE ASSEMBLY.
3. INSTALL CHECK VALVE WITH FLOW ARROW IN DIRECTION OF FLOW.
4. VALVE MAY BE INSTALLED VERTICALLY OR HORIZONTALLY.

INSPECTION DISASSEMBLY:

1. ISOLATE VALVE FROM SYSTEM PRESSURE BY CLOSING UPSTREAM AND DOWNSTREAM SHUT-OFF VALVES.
2. REMOVE COVER BOLTS.
3. REMOVE COVER AND O-RING.
4. LIFT GATE ASSEMBLY AND INSPECT VALVE SEAT RING AND GATE ASSEMBLY FOR DAMAGE. REPLACE PARTS IF NECESSARY.

VALVE REASSEMBLY:

1. AFTER REPLACEMENT OR INSPECTION OF INTERNAL COMPONENTS, REASSEMBLE VALVE IN REVERSE ORDER OF DISASSEMBLY INSTRUCTIONS.
2. IF VALVE LEAKS AROUND SHAFT PACKING, TURN PACKING NUT CLOCKWISE UNTIL LEAKING HALTS.

RECOMMENDED SPARE PARTS FOR  
 FLOMATIC 4" & 6" SERIES 92, 92LW, 92LS

<u>DESCRIPTION</u>	<u>QUANTITY</u>
DISC	1
SEAT RING	1
PACKING	1
SHAFT KEY	3
COVER O-RING	1
SHAFT (BEARING) O-RING	2
SEAT RING O-RING	1

MANUFACTURED IN  
 COMPLIANCE WITH  
 AWWA C508 STANDARD

Fromatic Corporation can accept no responsibility for possible errors in catalogues, brochures and other printed material. Fromatic Corporation reserves the right to alter its products without notices. This also applies to product already agreed. All trademarks in this material are property of the respective companies. All right reserved. ©2011 Fromatic Corporation. The drawings & information on this drawing sheet are the sole & exclusive property of Fromatic Corporation. Any reproduction, distribution, display or use of these drawings or information in whole or in part without written authorization of Fromatic Corporation is strictly prohibited.