

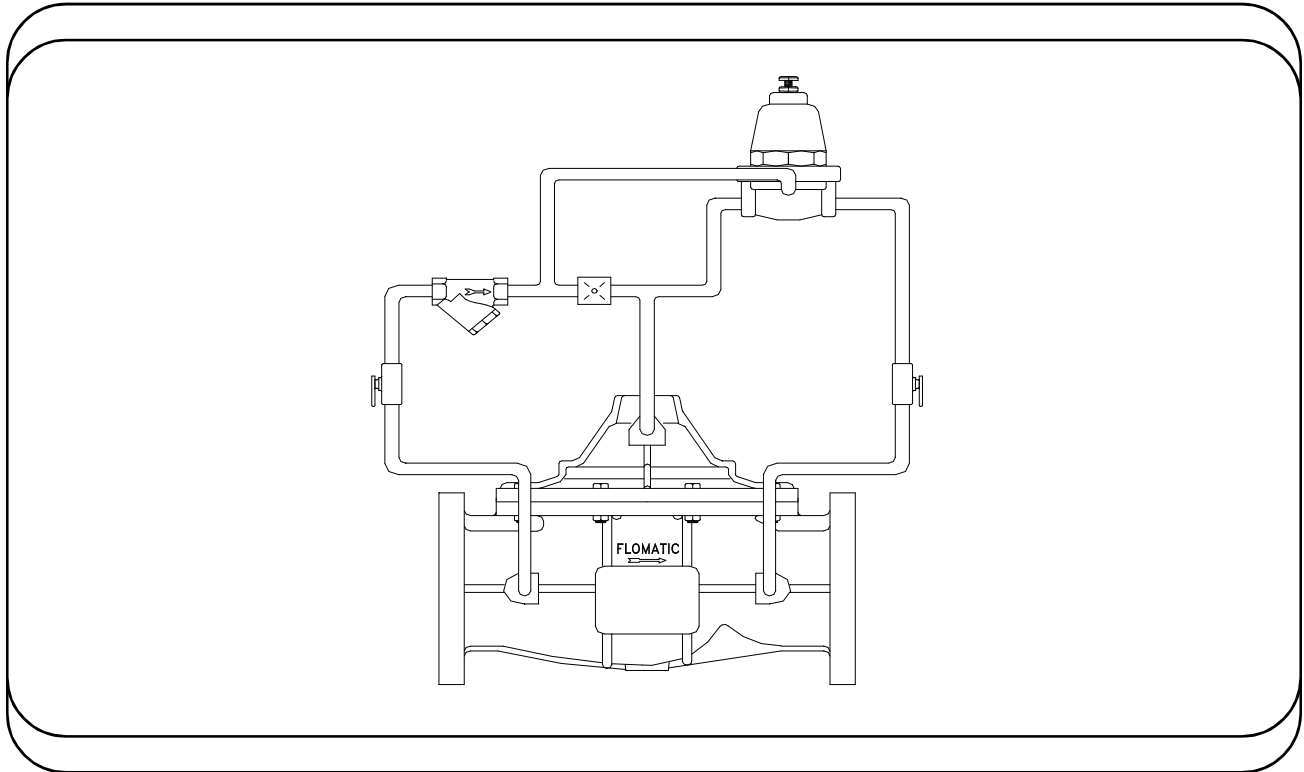

Operation & Maintenance Manual

Place this manual with valve, or person responsible for maintenance of the valve



Model C401/CF401-Pressure Relief Valve

YOUR PRODUCT INFORMATION:

Model Number: _____

Date: _____

Serial Number: _____

Valve Size: _____

Factory Pilot Preset: _____ *psi*

High Quality Valves Built to Last...



15 PRUYN'S ISLAND DRIVE
GLENS FALLS, NY 12801

800-833-2040 * 518-761-9797 * Fax: 518-761-9798
worldwideweb://www.flomatic.com * e-mail: flomatic@flomatic.com

FILE: C401

PRESSURE RELIEF VALVE

The Model C401 Pressure Relief Valve protects against pressure in pump stations, distribution systems and transmission mains by opening when inlet pressure exceeds a preset valve and discharging high pressure water to waste pump suction or a zone of lower pressure.

The hydraulic pilot valve senses inlet pressure and reacts rapidly to an over pressure causing the relief valve to open to a throttled position which permits discharge of a sufficient volume of high pressure water to prevent a pressure rise above its setting.

Part List

1. Shut-Off Valve
2. Strainer
3. Orifice (Needle Valve)
4. Pilot Valve

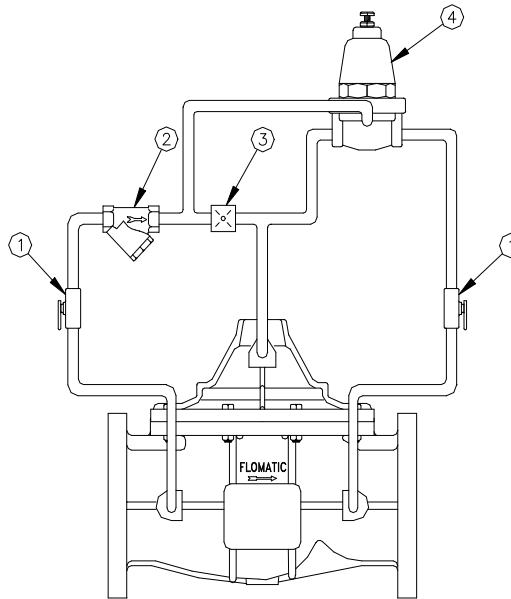

SHIPMENT:

When shipped, controls are usually mounted on the main valve. If control subassemblies are shipped separately, all connections are tagged to insure correct assembly.

INSTALLATION:

1. Flush the pipeline before inserting the valve.
2. Install the valve with the "arrow" on body pointing in the direction of flow.
3. Attach subassemblies to main valve if necessary.
4. If gauge cocks are not assembled, install at the back side of the valve.
5. Allow enough clearance above valve for removal of piston assembly.

START-UP:

1. Install pressure gauges to observe inlet and outlet pressures.
2. Open the shut-off valve on the level control assembly.
3. Open 1/8" air bleeder at the top of the valve. (Reclose after step 4 or step 5.)
4. Open main line shut-off valve (usually a gate or butterfly valve) on the outlet side of the relief valve approximately 1/10 of the way to the limit the flow through the relief or back pressure valve during step 5.
5. Open main line shut-off valve on the inlet side of the relief valve and observe inlet pressure gauge. After air has been vented from above diaphragm, the relief valve will gradually close and the inlet side pressure gauge will indicate the normal supply static or pump pressure.
6. If back pressure setting is too high, turn the pilot adjustment screw slowly counter clockwise, if the back pressure setting is too low, turn the pilot adjusting screw slowly clockwise.
7. If the back pressure or relief valve does not fully close in step 5, turn the adjusting screw of the pilot valve clockwise slowly until full closure is achieved.

Information needed to order replacement parts:

Valve Size _____

Serial # _____

Model # C401/CF401

Main Valve

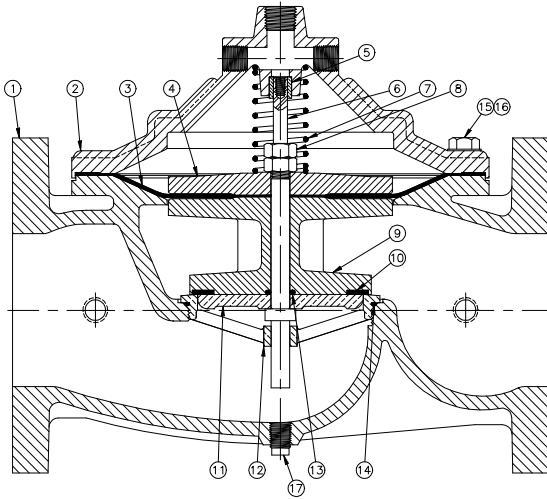

ITEM	QTY.	DESCRIPTION	MATERIAL
1	1	BODY	DUCTILE IRON
2	1	COVER	DUCTILE IRON
3	1	DIAPHRAGM	NITRILE/NYLON
4	1	DIAPHRAGM PLATE	CAST IRON
5	1	BUSHING	BRONZE
6	1	STEM	STAINLESS STEEL
7	1	SPRING	STAINLESS STEEL
8	2	STEM NUT	STAINLESS STEEL
9	1	SPOOL	CAST IRON
10	1	SEAT SEAL	BUNA-N
11	1	SEAT PLATE	FEDERALLOY
12	1	SEAT RING	FEDERALLOY
13	1	STEM O-RING	BUNA-N
14	1	SEAT RING O-RING	BUNA-N
15	A/R	BOLT & NUT	STAINLESS STEEL
16	A/R	WASHER	STAINLESS STEEL
17	1	DRAIN PLUG	STAINLESS STEEL

Exterior Valve Components

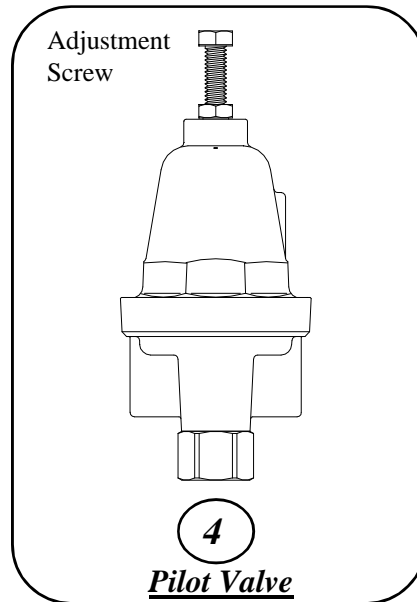
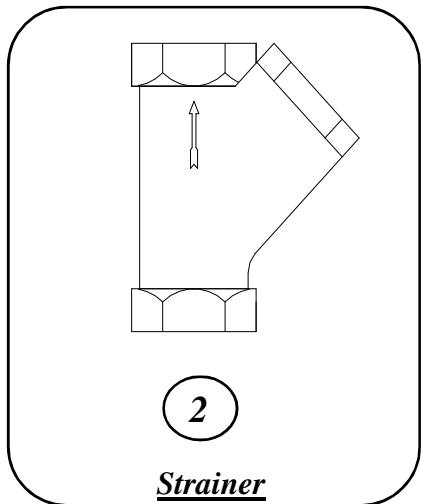
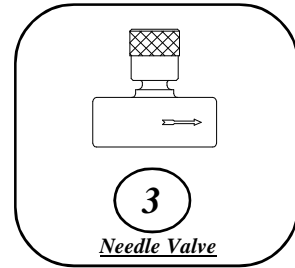
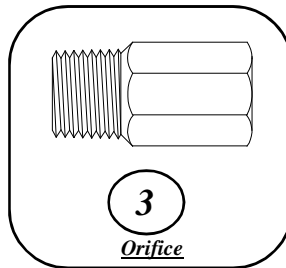
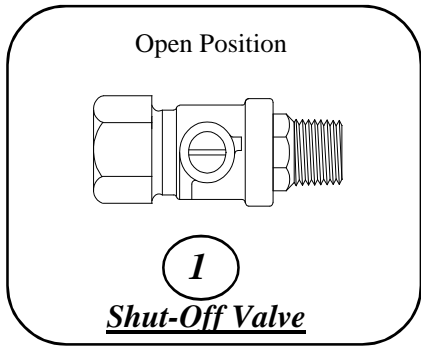

TROUBLE SHOOTING GUIDE

A. PROBLEM : Valve opens and will not close resulting in excessive outlet pressure.

CAUSE

1. Main valve is air bound.
2. Shut-off (isolation) valve at the inlet side of controls is closed.
3. Indicator stuffing box or sight glass is leaking.
4. Ruptured diaphragm in pilot valve. (Evidenced by leak from vent hole in spring chamber.)
5. Fouled orifice or needle valve.
6. Fouled strainer.
7. Damaged pilot valve seat.
8. Ruptured diaphragm in main valve.
9. Sticks or stones lodged under seat of main valve.
10. Worn seat packing and/or seat ring in main valve.
11. Incorrect adjustment of pilot valve (set too low).
12. Leakage from one or more fittings in the controls.
13. Damaged o-ring stem seal.

CORRECTION

1. Open 1/8" air bleeder at the top of valve to release air.
2. Open shut-off valve.
3. Tighten packing nut or replace packing seals.
4. Replace diaphragm.
5. Open needle valve wide (counter clockwise) to flush seat, & after 4 or 5 seconds return to original setting, or remove and clean orifice.
6. Disassemble, clean or replace screen.
7. Disassemble, clean and replace damaged parts.
8. Disassemble and replace diaphragm.
9. Disassemble and remove. Replace damaged parts.
10. Disassemble and replace damaged parts.
11. For back pressure valve turn adjusting screw clockwise slowly until valve resumes control and the desired inlet pressure is obtained. For relief valve, turn pilot adjusting screw clockwise until valve closes.
12. Tighten or replace fitting.
13. Disassemble and replace o-ring.

B. PROBLEM: Valve is closed and will not open.

CAUSE

1. Incorrect adjustment of pilot valve. (Set too high)
2. Needle valve (if installed) open too far.
3. Shut off (isolation) valve at the outlet side of the controls is closed.
4. Fouled pilot valve
5. Worn or eroded orifice (or needle valve seat).

CORRECTION

1. For back pressure turn pilot valve adjusting screw counter clockwise slowly until the valve opens and the desired inlet pressure is obtained. For relief valve turn pilot adjusting screw counter clockwise slowly until the valve opens, then turn clockwise till valve closes.
2. Turn adjusting cap clockwise slowly until valve opens and a reduced outlet pressure is observed. Lock in this position.
3. Open shut-off valve.
4. Disassemble and clean. If necessary, replace stem and seat ring.
5. Replace orifice (or needle valve).

Test To Isolate Source Of Problem

(After visual inspection of external leaks)

1. With the main line gate valves open and the back pressure (relief) valve under pressure, close the control shut-off (isolation) valve at the outlet side of the back pressure (relief) pilot control. **THE MAIN VALVE SHOULD CLOSE.**

If the valve remains fully open the source of the problem could be:

(A) fouled orifice or needle; (B) fouled strainer; (C) control shut off valve at inlet is closed; (D) ruptured main valve diaphragm.

If the valve is partially closed the source of the problem could be:

(A) damaged: main valve seat packing or seat ring; (B) debris under seat; (C) main valve is air-bound; (D) damaged stem o-ring.

If the valve closes fully, the source of the problem could be:

(A) pilot valve out of adjustment; (B) damaged pilot valve stem or set ring; (C) partially fouled strainer or needle valve.

2. With the main line gate valves open and the back pressure (relief) valve under pressure, close both shut-off (isolation) valves (inlet and outlet sides) in the controls and open the air bleeder pet cock to release water from the power chamber above the diaphragm of the main valve. Water will flow from the pet cock as the piston of the main valve moves to the full open position.

If water continues to flow from the pet cock, the source of the problem could be:

(A) damaged: main valve diaphragm or stem seal o-ring; (B) loose locknut.