

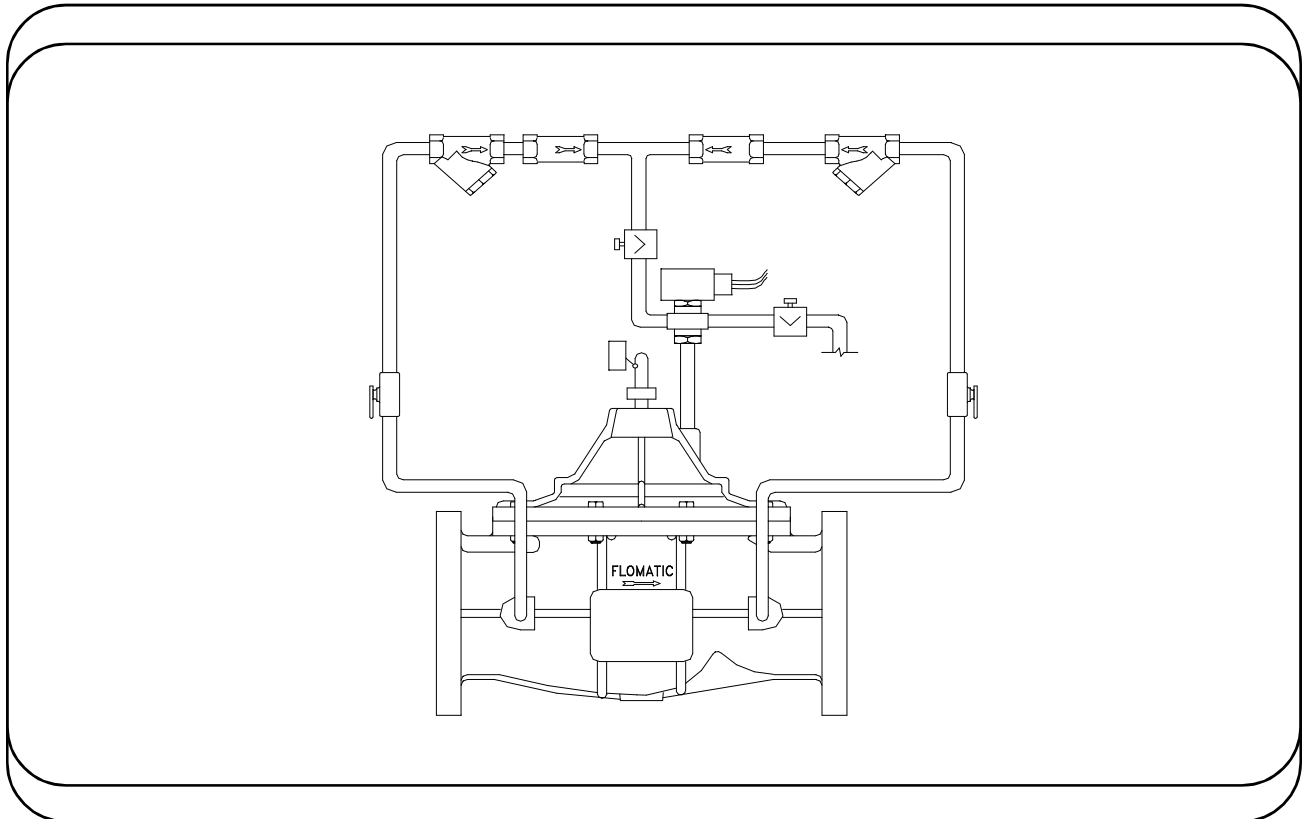

Operation & Maintenance Manual

Place this manual with valve, or person responsible for maintenance of the valve



Model C601/CF601-Pump Control Valve

YOUR PRODUCT INFORMATION:

Model Number: _____

Date: _____

Serial Number: _____

Valve Size: _____

Solenoid _____

High Quality Valves Built to Last...



15 PRUYN'S ISLAND DRIVE
GLENS FALLS, NY 12801

800-833-2040 * 518-761-9797 * Fax: 518-761-9798
worldwideweb://www.flomatic.com * e-mail: flomatic@flomatic.com

FILE: C601

PUMP CONTROL VALVE

The Model C601 Pump Control Valve protects against downstream pressure surges by placing the pump on line slowly and taking it off line slowly.

When the pump starts, a three-way solenoid valve is energized to open the pump control valve at a slow, controlled rate by discharging control water from above the diaphragm (piston) to waste through an adjustable needle valve.

To shut down the pump, the three-way solenoid valve is de-energized to introduce control water above the piston (through an adjustable needle valve) causing it to close slowly against the running pump. Just prior to full closure of the valve piston, the indicator rod opens a limit switch stop the pump.

Part List

1. Shut-Off Valve
2. Strainer
3. Needle Valve (Closing Speed Control)
4. Needle Valve (Opening Speed Control)
5. Three-Way Solenoid
6. Limit Switch
7. Check Valve
8. Finger Strainer

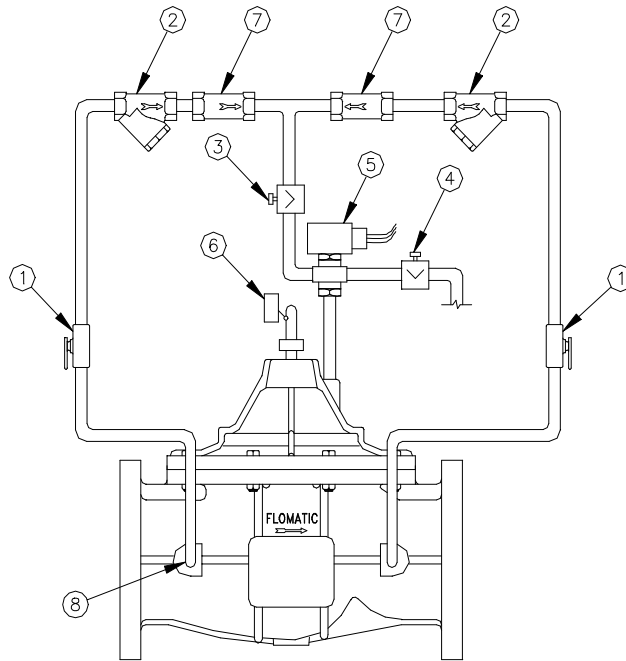

SHIPMENT:

When shipped, controls are usually mounted on the main valve. If control subassemblies are shipped separately, all connections are tagged to insure correct assembly.

INSTALLATION:

1. Flush the pipeline before inserting the valve.
2. Install the valve with the "arrow" on body pointing in the direction of flow (usually towards the tank or reservoir).
3. Attach subassemblies to main valve if necessary.
4. Install 1/4" pet cocks at the backside of valve.
5. Allow enough clearance above valve for removal of piston assembly.

START-UP:

1. Install pressure gauges to inlet and outlet.
2. Open both shut-off valves on the control assembly.
3. Open 1/8" air bleeder at the top of the valve. (Re-close after step 4 or step 5.)
4. Open main line shut-off valve (usually a gate or butterfly valve) on the outlet side of the main valve about 1/4 open.
5. Slowly open main line shut-off valve on the inlet side and observe pressure gauges. When the outlet pressure gauge shows that the downstream pressure is being controlled, this shut-off valve may be opened more rapidly.
6. If the outlet pressure requires adjustment, turn the adjusting screw of the pilot valve counter clockwise to decrease, clockwise to increase. **CAUTION:** any adjustment should be done slowly.

Information needed to order replacement parts:

Valve Size _____

Serial # _____

Model # C601

Main Valve

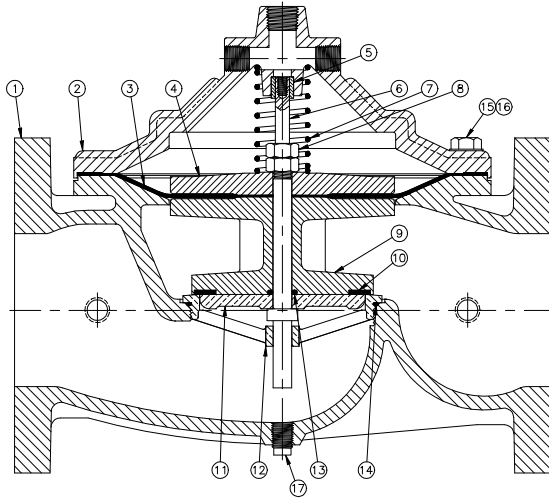

ITEM	QTY.	DESCRIPTION	MATERIAL
1	1	BODY	DUCTILE IRON
2	1	COVER	DUCTILE IRON
3	1	DIAPHRAGM	NITRILE/NYLON
4	1	DIAPHRAGM PLATE	CAST IRON
5	1	BUSHING	BRONZE
6	1	STEM	STAINLESS STEEL
7	1	SPRING	STAINLESS STEEL
8	2	STEM NUT	STAINLESS STEEL
9	1	SPOOL	CAST IRON
10	1	SEAT SEAL	BUNA-N
11	1	SEAT PLATE	FEDERALLOY
12	1	SEAT RING	FEDERALLOY
13	1	STEM O-RING	BUNA-N
14	1	SEAT RING O-RING	BUNA-N
15	A/R	BOLT & NUT	STAINLESS STEEL
16	A/R	WASHER	STAINLESS STEEL
17	1	DRAIN PLUG	STAINLESS STEEL

Exterior Valve Components

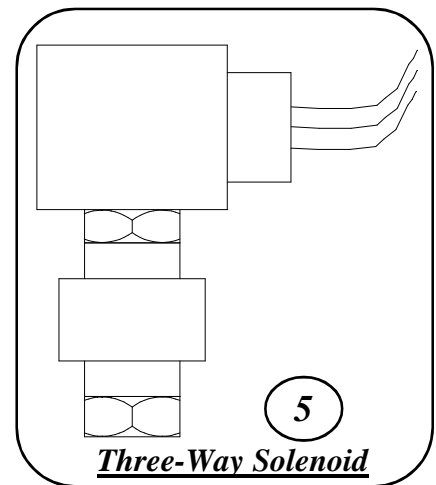
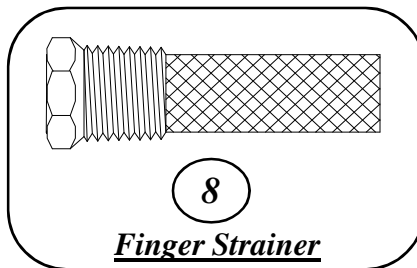
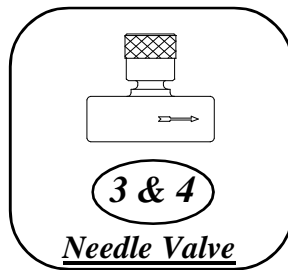
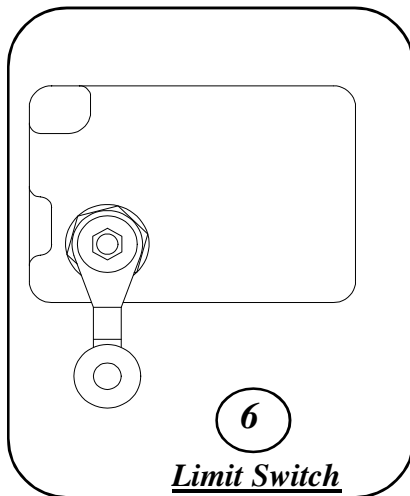
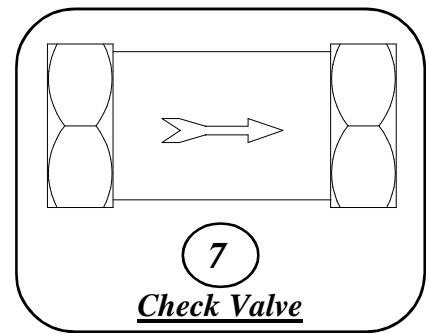
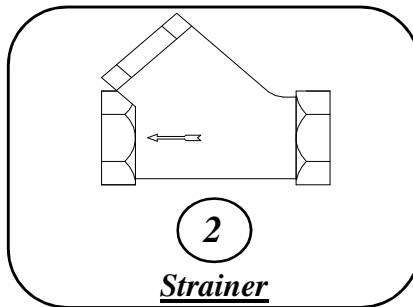
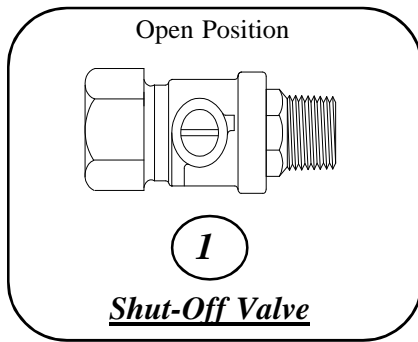

TROUBLE SHOOTING GUIDE

A. PROBLEM : Valve is open and will not regulate flow.

CAUSE	CORRECTION
1. Main valve is air bound.	1. Open 1/8" air bleeder at the top of valve to release air.
2. Shut-off (isolation) valve at the outlet side of valve is closed.	2. Open shut-off valve.
3. Damaged or fouled solenoid pilot seat or core tube assembly of solenoid pilot valve.	3. Clean or replace solenoid pilot.
4. Fouled needle valve.	4. Open needle valve (counter clockwise) to flush seat, & after 4 or 5 seconds return to original setting, or remove and clean orifice.
5. Fouled strainer.	5. Disassemble, clean or replace screen.
6. Ruptured diaphragm in main valve.	6. Replace diaphragm.
7. Debris lodged under the seat of main valve.	7. Disassemble, clean and replace damaged parts.
8. Worn seat packing and/or seat ring in main valve.	8. Disassemble, clean and replace damaged parts.
9. Leaking in plumbing fittings.	9. Tighten or replace fitting.
10. Damaged O-ring stem seal.	10. Disassemble and replace O-ring.
11. Outlet check valve is stuck open.	11. Replace check valves.

B. PROBLEM: Valve is closed and will not open.

1. Coil of N.C. solenoid pilot is burned out.	1. Replace coil.
2. Fouled solenoid pilot.	2. Clean or replace solenoid pilot.
3. Pilot is adjusted to low.	3. Adjust pilot.
4. Needle valve #3 is open wider the needle valve #4	4. Adjust needle valves.

Test To Isolate Source Of Problem

(After visual inspection of external leaks)

1. With the main line gate valves open and the reducing valve pressurized, close the control shut-off (isolation) valve at the outlet side of the pressure reducing pilot control. **THE MAIN VALVE SHOULD CLOSE.**

If the valve remains fully open the source of the problem could be:

(A) fouled orifice or needle; (B) fouled strainer; (C) control shut off valve at inlet is closed; (D) ruptured main valve diaphragm.

If the valve is partially closed the source of the problem could be:

(A) damaged: main valve seat packing or seat ring; (B) debris under seat; (C) main valve is air-bound; (D) damaged stem O-ring.

If the valve closes fully, the source of the problem could be:

(A) pilot valve out of adjustment; (B) damaged pilot valve stem or set ring; (C) partially fouled strainer or needle valve.

2. With the main line gate valves open and the reducing valve pressurized, close both shut-off (isolation) valves and open the air bleeder pet cock to release water out of the power chamber above the diaphragm of the reducing valve. Water will flow from the pet cock as the valve moves to the full open position.

If water continues to flow, the source of the problem could be:

(A) damaged: main valve diaphragm or stem seal O-ring; (B) loose locknut.