

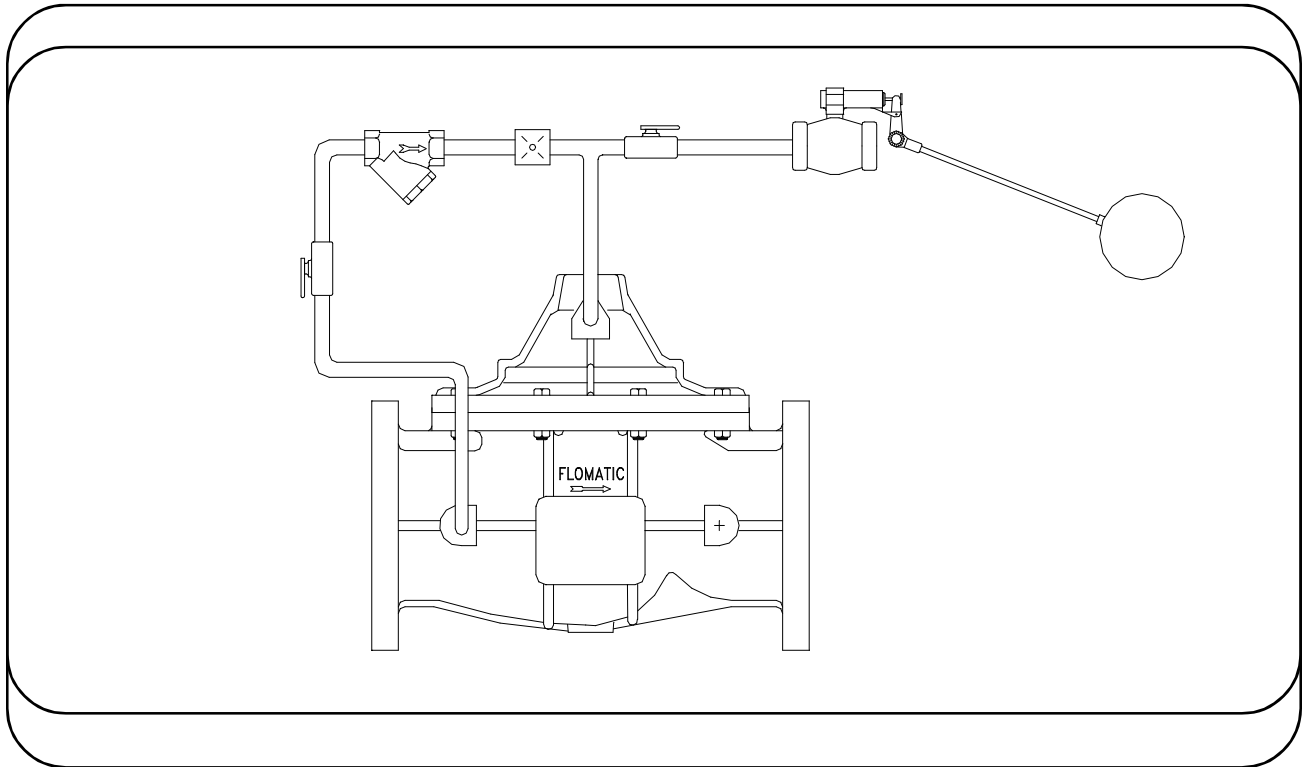

# Operation & Maintenance Manual

Place this manual with valve, or person responsible for maintenance of valve



## Model C701/CF701-Float Valve (Pilot Operated)

### **YOUR PRODUCT INFORMATION:**

**Model Number:** \_\_\_\_\_

**Date:** \_\_\_\_\_

**Serial Number:** \_\_\_\_\_

**Valve Size:** \_\_\_\_\_

**Float Model Number:** \_\_\_\_\_

*High Quality Valves Built to Last...*



15 PRUYN'S ISLAND DRIVE  
GLENS FALLS, NY 12801

800-833-2040 \* 518-761-9797 \* Fax: 518-761-9798  
worldwideweb://www.flomatic.com \* e-mail: flomatic@flomatic.com

FILE: C701  
Rev 2

## FLOAT VALVE (PILOT OPERATED)

The Model C701 Float Valve (Pilot Operated) closes at high water level to prevent overflow of a ground storage tank, basin or reservoir and opens to refill when the water level lowers 1 to 2 inches.

Normally this valve is either full open or full closed, however the design characteristics of its controls causes the main valve piston to modulate (close slowly) over the last few inches of filling.

(For most applications the float operated pilot valve should be installed in a "stilling well" to avoid erratic operation caused by waved action.)

### Part List

1. Shut-Off Valve
2. Strainer
3. Orifice (Needle Valve)
4. Pilot Valve
5. Finger Strainer

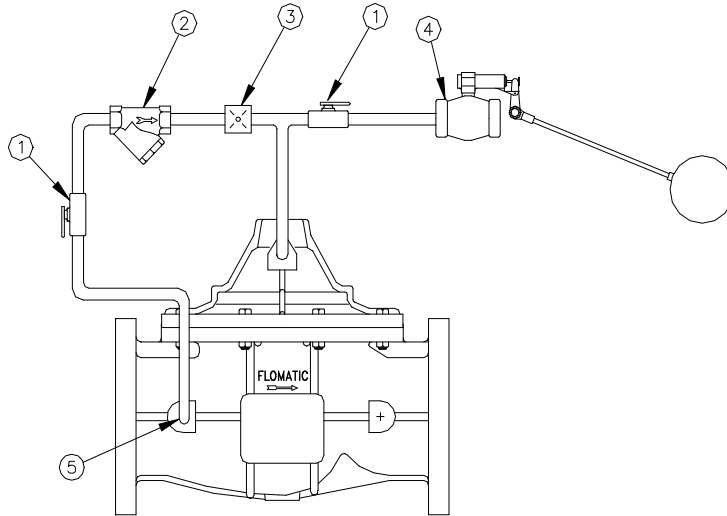

### SHIPMENT:

When shipped, controls are usually mounted on the main valve. If control subassemblies are shipped separately, all connections are tagged to insure correct assembly.

### INSTALLATION:

1. Flush the pipeline before inserting the valve.
2. Install the valve with the "arrow" on body pointing towards the reduced pressure area (or with the flange tagged "INLET" toward the high pressure area).
3. Attach subassemblies to main valve if necessary.
4. Install 1/4" pet cocks at the backside of valve.
5. Allow enough clearance above valve for removal of piston assembly.

### START-UP:

1. Install pressure gauges to inlet and outlet pressures.
2. Open both shut-off valves on the control assembly.
3. Open 1/8" air bleeder at the top of the valve. (Re-close after step 4 or step 5.)
4. Open main line shut-off valve (usually a gate or butterfly valve) on the outlet side of the main valve about 1/4 open.
5. Slowly open main line shut-off valve on the inlet side and observe pressure gauges. When the outlet pressure gauge shows that the downstream pressure is being controlled, this shut-off valve may be opened more rapidly.
6. If the outlet pressure requires adjustment, turn the adjusting screw of the pilot valve counter clockwise to decrease, clockwise to increase. CAUTION: any adjustment should be done slowly.

**Information needed to order replacement parts:**

Valve Size \_\_\_\_\_

Serial # \_\_\_\_\_

Model # C701

**Main Valve**

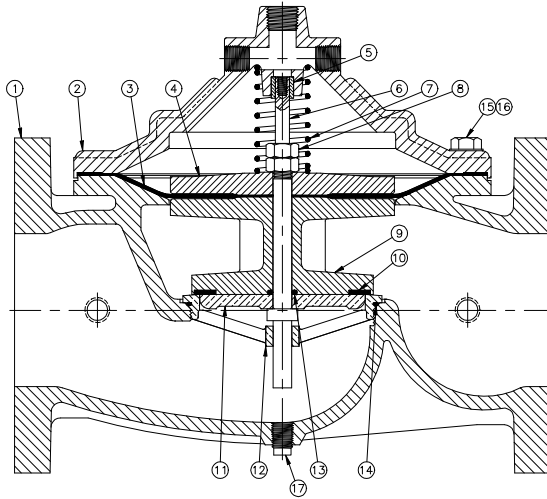

ITEM	QTY.	DESCRIPTION	MATERIAL
1	1	BODY	DUCTILE IRON
2	1	COVER	DUCTILE IRON
3	1	DIAPHRAGM	NITRILE/NYLON
4	1	DIAPHRAGM PLATE	CAST IRON
5	1	BUSHING	BRONZE
6	1	STEM	STAINLESS STEEL
7	1	SPRING	STAINLESS STEEL
8	2	STEM NUT	STAINLESS STEEL
9	1	SPOOL	CAST IRON
10	1	SEAT SEAL	BUNA-N
11	1	SEAT PLATE	FEDERALLOY
12	1	SEAT RING	FEDERALLOY
13	1	STEM O-RING	BUNA-N
14	1	SEAT RING O-RING	BUNA-N
15	A/R	BOLT & NUT	STAINLESS STEEL
16	A/R	WASHER	STAINLESS STEEL
17	1	DRAIN PLUG	STAINLESS STEEL

**Exterior Valve Components**

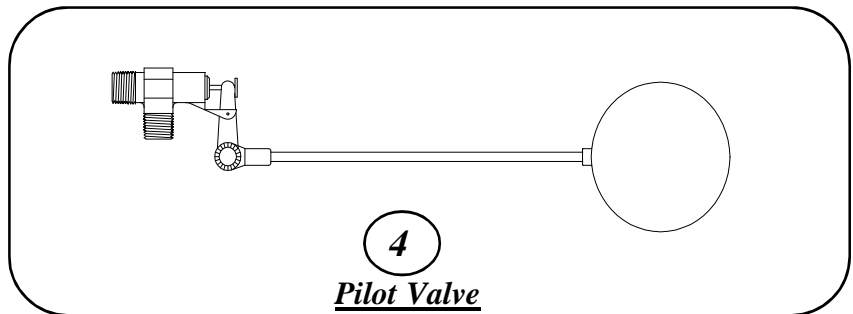
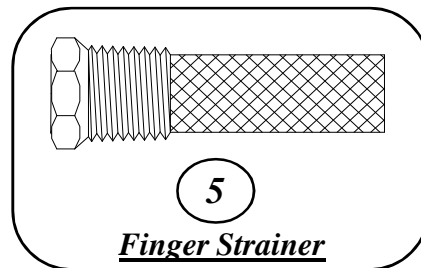
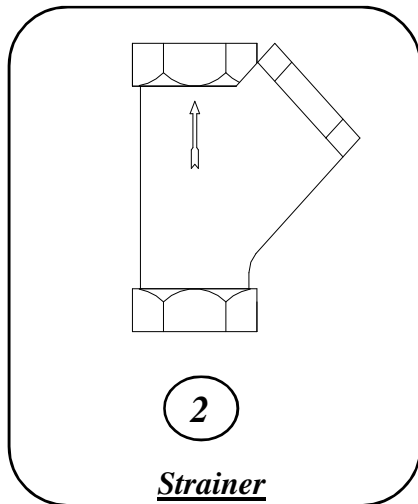
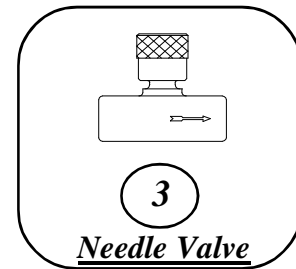
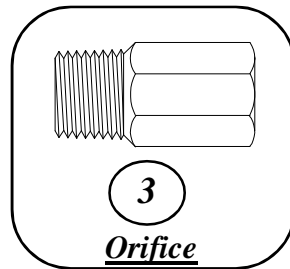
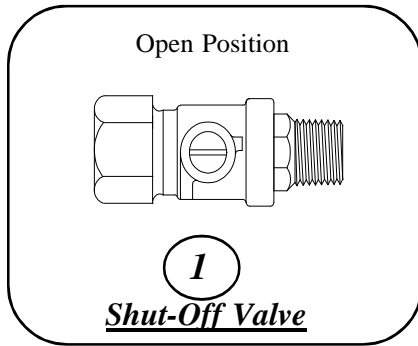

## TROUBLE SHOOTING GUIDE

### A. PROBLEM : Valve opens and will not close resulting in excessive outlet pressure.

#### CAUSE

1. Main valve is air bound.
2. Shut-off (isolation) valve at the outlet side of control is closed.
3. Indicator stuffing box or sight glass is leaking.
4. Ruptured diaphragm in pilot valve. (Evidenced by leak from vent hole in spring chamber.)
5. Fouled orifice or needle valve.
6. Fouled strainer.
7. Damaged pilot valve seat.
8. Ruptured diaphragm in main valve.
9. Sticks or stones lodged under seat of main valve.
10. Worn seat packing and/or seat ring in main valve.
11. Incorrect adjustment of pilot valve (set too high).
12. Leakage from one or more fittings in the controls.
13. Damaged O-ring stem seal.

#### CORRECTION

1. Open 1/8" air bleeder at the top of valve to release air.
2. Open shut-off valve.
3. Tighten packing nut or replace packing seals.
4. Replace diaphragm.
5. Open needle valve wide (counter clockwise) to flush seat, & after 4 or 5 seconds return to original setting, or remove and clean orifice.
6. Disassemble, clean or replace screen.
7. Disassemble, clean and replace damaged parts.
8. Disassemble and replace diaphragm.
9. Disassemble and remove. Replace damaged parts.
10. Disassemble and replace damaged parts.
11. For back pressure valve turn adjusting screw counter clockwise slowly until valve resumes control and the desired outlet pressure is obtained.
12. Tighten or replace fitting.
13. Disassemble and replace O-ring.

### B. PROBLEM: Valve is closed and will not open.

1. Incorrect adjustment of pilot valve. (Set too low)
2. Needle valve (if installed) open too far.
3. Shut off (isolation) valve at the outlet side of the controls is closed.
4. Fouled pilot valve
5. Worn or eroded orifice (or needle valve seat).

1. Turn pilot valve adjusting screw clockwise slowly until the valve opens and the desired outlet pressure is obtained.
2. Turn adjusting cap clockwise slowly until valve opens and a reduced outlet pressure is observed. Lock in this position.
3. Open shut-off (isolation) valve.
4. Disassemble and clean, replace seat ring/packing is necessary.
5. Replace orifice (or needle valve).

### C. PROBLEM: Valve hunts or chatters (evidenced by rapidly changing outlet pressure).

1. Valve is oversized.
2. Flow control valve (or needle-valve at the outlet side of controls) is out of adjustment.
3. Pilot valve seat packing is damaged.

1. Install a smaller pressure reducing valve in a bypass around the oversized valve to handle low flows and provide better control.
2. Slowly turn adjusting cap counter clockwise until the outlet pressure becomes steady.
3. Replace seat packing.

## Test To Isolate Source Of Problem

(After visual inspection of external leaks)

1. With the main line gate valves open and the reducing valve pressurized, close the control shut-off (isolation) valve at the outlet side of the pressure reducing pilot control. **THE MAIN VALVE SHOULD CLOSE.**

#### **If the valve remains fully open the source of the problem could be:**

*(A) fouled orifice or needle; (B) fouled strainer; (C) control shut off valve at inlet is closed; (D) ruptured main valve diaphragm.*

#### **If the valve is partially closed the source of the problem could be:**

*(A) damaged: main valve seat packing or seat ring; (B) debris under seat; (C) main valve is air-bound; (D) damaged stem O-ring.*

#### **If the valve closes fully, the source of the problem could be:**

*(A) pilot valve out of adjustment; (B) damaged pilot valve stem or set ring; (C) partially fouled strainer or needle valve.*

2. With the main line gate valves open and the reducing valve pressurized, close both shut-off (isolation) valves and open the air bleeder pet cock to release water out of the power chamber above the diaphragm of the reducing valve. Water will flow from the pet cock as the valve moves to the full open position.

#### **If water continues to flow, the source of the problem could be:**

*(A) damaged: main valve diaphragm or stem seal O-ring; (B) loose locknut.*