

Control Valve Cycle Gard®

Model C153S6



Flomatic Corporation

Size 1-1/4" X 1" / 32 mm X 25mm
1" / 25mm Internals

Materials

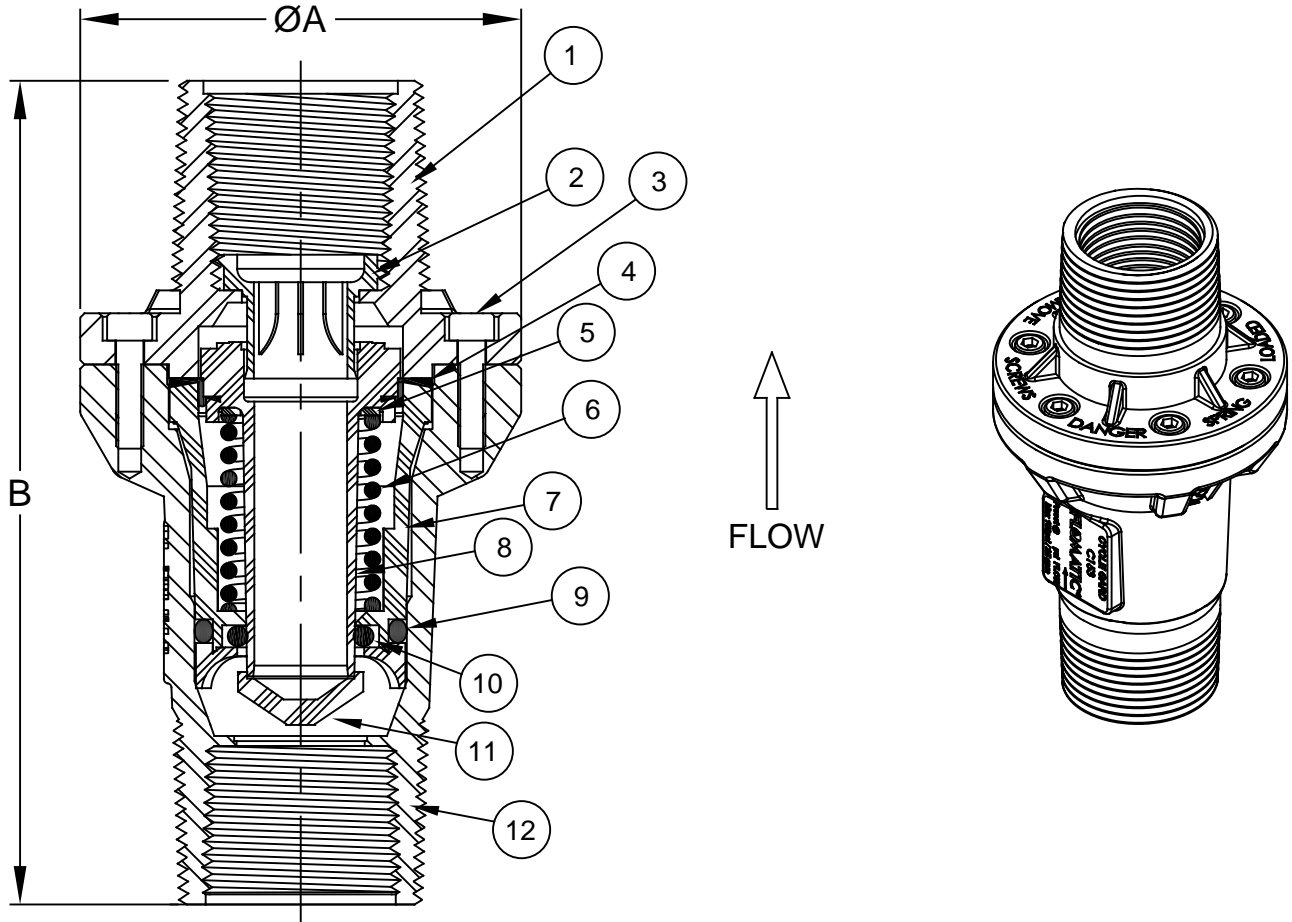

Item #	Qty	Description	Material	Item #	Qty	Description	Material
1	1	Cover	Stainless Steel 304	7	1	Cup	Thermoplastic Eng Grade
2	1	Seat	Thermoplastic Eng Grade	8	1	Stem	Thermoplastic Eng Grade
3	1	SHCS	Stainless Steel 18-8	9	1	Cartridge O'Ring	Buna-n
4	1	Diaphragm	Buna-n	10	1	Seat O'Ring	Buna-n
5	1	Washer	Thermoplastic Eng Grade	11	1	Seat	Thermoplastic Eng Grade
6	1	Spring	Stainless Steel 302	12	1	Body	Stainless Steel 304

Dimensions (1-1/4" MNPT X 1" FNPT BOTH ENDS)

Max Temp 90°F (32°C)
Max Pressure 150psi (10bar)

Size		Part #	A		B		Pressure Setting		Weight	
inch	mm		inch	mm	inch	mm	psi	bar	lbs	kg
1	25	C153002S6C	3-1/16	78	5-3/4	146	70	4.8	3.9	1.8

Flomatic Corporation can accept no responsibility for possible errors in catalogues, brochures and other printed material. Flomatic Corporation reserves the right to alter its products without notices. This also applies to product already agreed. All trademarks in this material are property of the respective companies. All right reserved. ©2018 Flomatic Corporation. The drawings & information on this drawing sheet are the sole & exclusive property of Flomatic Corporation. Any reproduction, distribution, display or use of these drawings or information in whole or in part without written authorization of Flomatic Corporation is strictly prohibited. www.flomatic.com



August 21, 20017
Dwg No: SC153S-70 Rev: B (10/18)

FLOMATIC CORPORATION
GLENS FALLS, N.Y. 12801
PHONE (518) 761-9797
FAX (518) 761-9798