

Control Valve

Cycle Gard® I

Model C152ET



Flomatic Corporation

Sizes 1" / 25 mm
Direct Acting Pump Control

LEAD FREE
NSF/ANSI 61

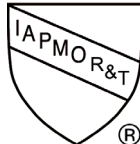

Materials

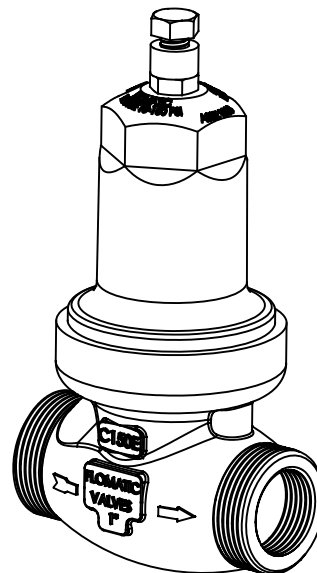
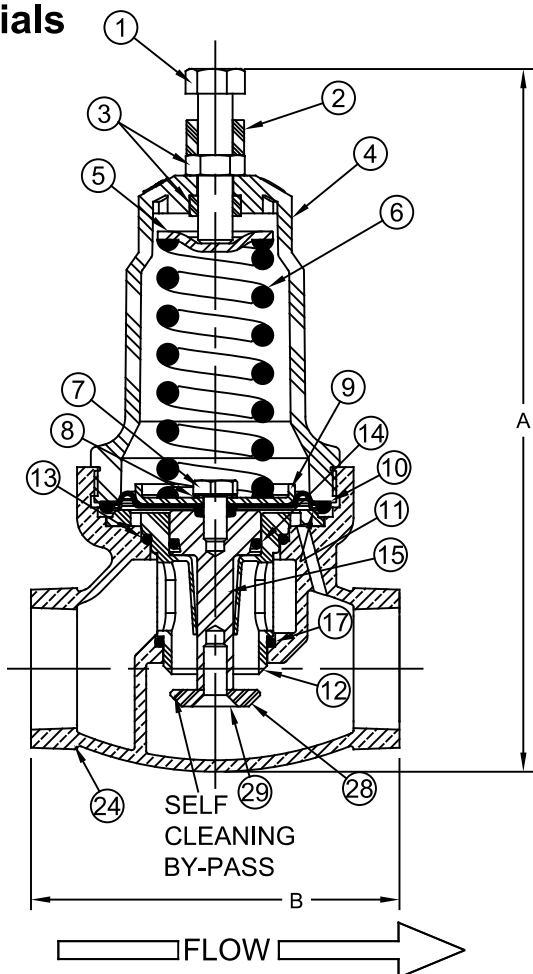

Max Temp 180°F (82°C)
Max Pressure 400psi (28bar)

Item #	Qty	Description	Material	Item #	Qty	Description	Material
1	1	Bolt	Steel	11	1	Friction Ring	Brass C36000
2	1	Spacer	ABS	12	1	Cartridge	Delrin®
3	2	Jam Nut	Stainless Steel 18-8	13	1	O-Ring (cartridge)	Buna-N
4	1	Cover	Noryl®	14	1	O-Ring (stem)	Buna-N
5	1	Spring Button	Stainless Steel 304	15	1	Stem	Stainless Steel 304
6	1	Spring	Music Wire	17	1	O-Ring (seat)	Buna-N
7	1	Bolt	Stainless Steel 304	24	1	Body	Bronze C89833
8	1	Tooth Lock Washer	Stainless Steel 304	28	1	Disc (slotted)	Stainless Steel 304
9	1	Diaphragm Plate	Stainless Steel 18-8	29	1	Bolt	Stainless Steel 18-8
10	1	Diaphragm	Nitrile/Nylon	Part Number C152001ET 15-75 psi Part Number C152101ET 15-150 psi			

Dimensions (1-1/4" MNPT X 1" FNPT both ends)

ANSI B1.20.1

Size		Part #	A		B		Weight	
inch	mm		inch	mm	inch	mm	lbs	kg
1	25	C152001ET	7-5/8	194	4	102	3.0	1.4

Flomatic Corporation can accept no responsibility for possible errors in catalogues, brochures and other printed material. Flomatic Corporation reserves the right to alter its products without notices. This also applies to product already agreed. All trademarks in this material are property of the respective companies. All rights reserved. ©2021 Flomatic Corporation. The drawings & information on this drawing sheet are the sole & exclusive property of Flomatic Corporation. Any reproduction, distribution, display or use of these drawings or information in whole or in part without written authorization of Flomatic Corporation is strictly prohibited. www.flomatic.com



November 6, 2018
Dwg No: SC152001ET Rev: A (2/21)

FLOMATIC CORPORATION
GLENS FALLS, N.Y. 12801
PHONE (518) 761-9797
FAX (518) 761-9798