

Control Valve

Pilot Valve

Model PRP



Sizes 3/8" / 10 mm
Pressure Reducing Pilot Valve

Materials (Stainless Steel)

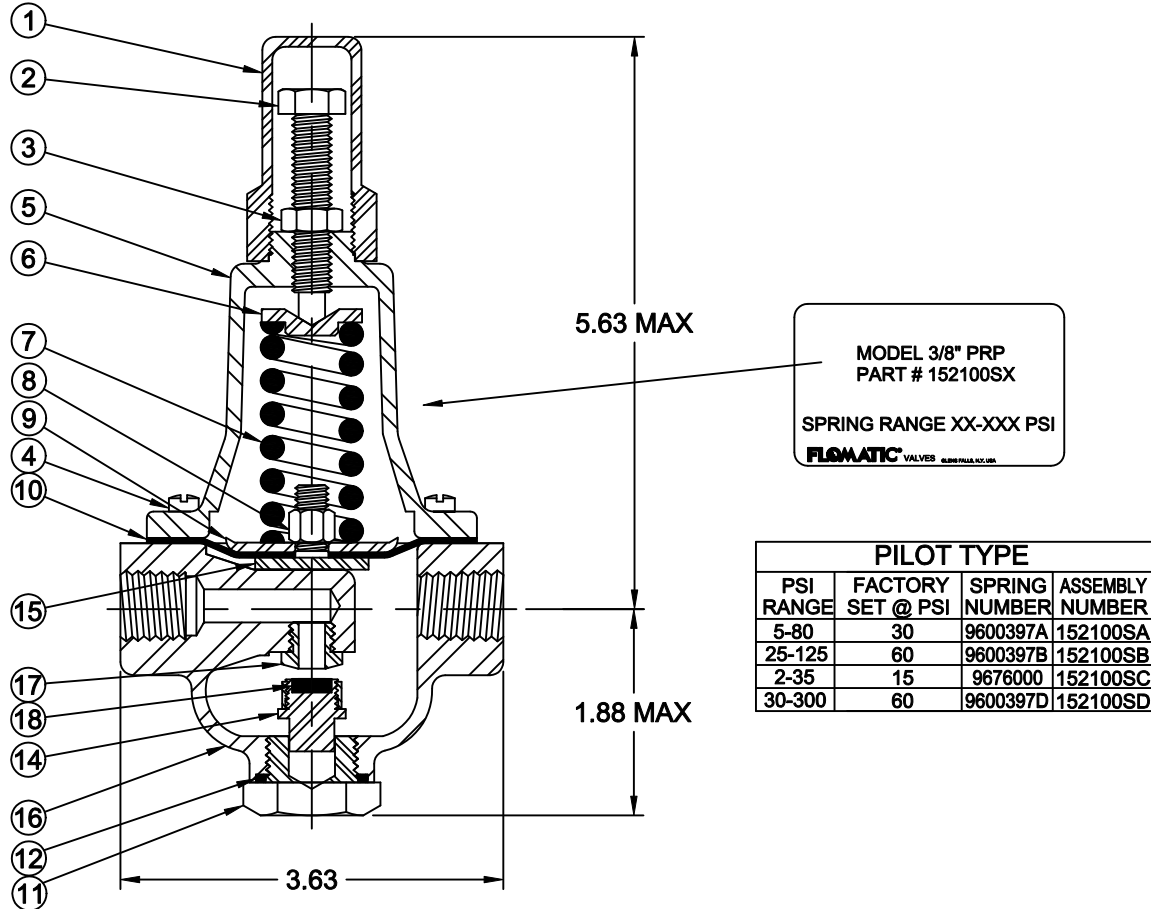

Item #	Qty	Description	Material	Item #	Qty	Description	Material
1	1	Adjustment Cap	ABS	10	1	Diaphragm	Buna-n/Nylon
2	1	Adjusting Screw	Stainless Steel 18-8	11	1	Body Plug	Stainless Steel 316
3	1	Jam Nut	Stainless Steel 18-8	12	1	O-Ring	Buna-n
4	8	Fillister Head Slotted Screw	Stainless Steel 18-8	13	1	3/8" Plug (not shown) Optional	Stainless Steel 316
5	1	Cover	Stainless Steel 316	14	1	Disc Retainer	Stainless Steel 316
6	1	Spring Button	Stainless Steel 304	15	1	Yoke	Stainless Steel 316
7	1	Spring	Steel	16	1	Body	Stainless Steel 316
8	1	Nut	Galvanized Steel	17	1	Seat	Stainless Steel 304
9	1	Diaphragm Plate	Stainless Steel 316	18	1	Disc	Buna-n

Fomatic Corporation can accept no responsibility for possible errors in catalogues, brochures and other printed material. Fomatic Corporation reserves the right to alter its products without notices. This also applies to product already agreed. All trademarks in this material are property of the respective companies. All right reserved. ©2011 Fomatic Corporation. The drawings & information on this drawing sheet are the sole & exclusive property of Fomatic Corporation. Any reproduction, distribution, display or use of these drawings or information in whole or in part without written authorization of Fomatic Corporation is strictly prohibited.



June 14, 2004
Dwg No: S152100S Rev: D (3/15)

FLOMATIC CORPORATION
GLENS FALLS, N.Y. 12801
PHONE (518) 761-9797
FAX (518) 761-9798