

# Backflow Preventer

Sizes 1-1/4" / 32mm

# Model GF8080S6



Glen-Flo® Valves



## Materials

DUAL CHECK  
MODEL GF8080S6  
S/N                      SIZE: 1-1/4"  
**GLEN-FLO**  
FLOW →  
175PSI/180°F

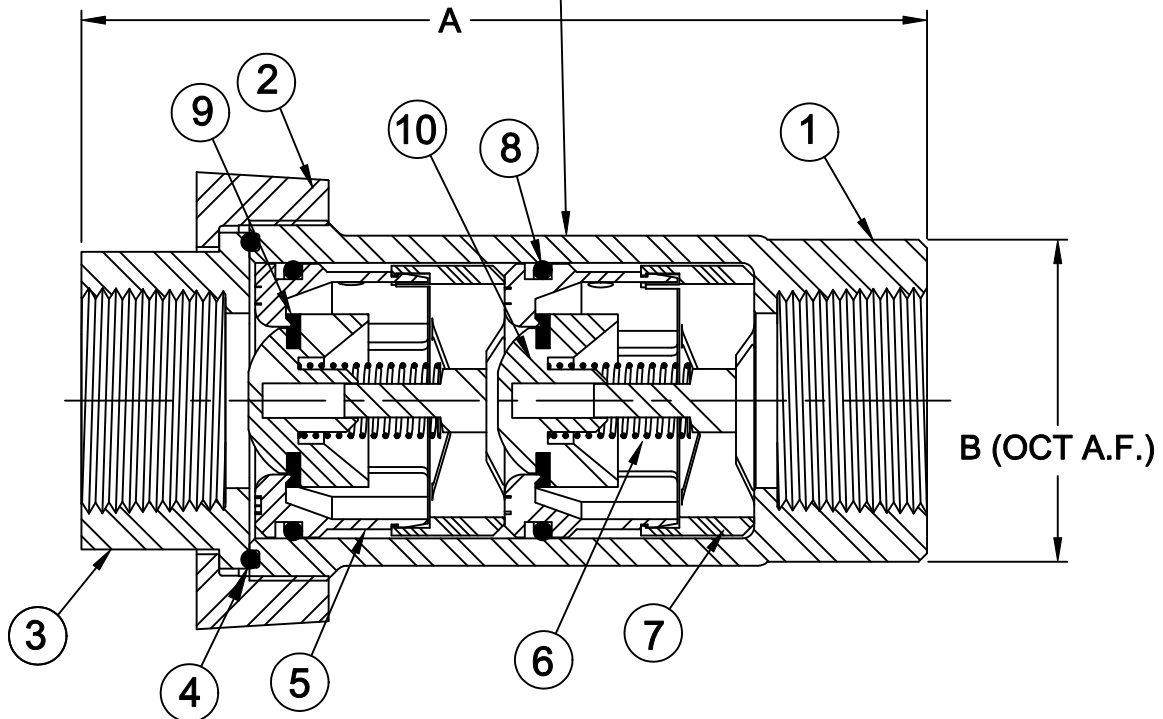

Max Temp 180°F (82°C)  
Max Pressure 175psi (12bar)

Item #	Qty	Description	Material	ASTM	Item #	Qty	Description	Material	ASTM
1	1	Body	Stainless Steel	316	6	2	CV Spring	Stainless Steel	316
2	1	Tailpiece Nut	Stainless Steel	316	7	2	CV Spring Retainer	Celcon	-----
3	1	Tailpiece	Stainless Steel	316	8	2	CV O'Ring	Buna-n	-----
4	1	Tailpiece O'Ring	Buna-n	-----	9	2	CV Disc	Silicone Rubber	Grade 40
5	2	CV Housing	Celcon	-----	10	2	CV Poppet	Noryl GFN2-780S	-----

CV = Check Valve

## Dimensions

Size		Part #	A		B		Weight	
Inch	mm		inch	mm	inch	mm	lbs	kg
1-1/4	32	GF8082S6	4-13/32	112	1-27/32	35	2.2	1.0

Flomatic Corporation can accept no responsibility for possible errors in catalogues, brochures and other printed material. Flomatic Corporation reserves the right to alter its products without notices. This also applies to product already agreed. All trademarks in this material are property of the respective companies. All right reserved. ©2015 Flomatic Corporation. The drawings & information on this drawing sheet are the sole & exclusive property of Flomatic Corporation. Any reproduction, distribution, display or use of these drawings or information in whole or in part without written authorization of Flomatic Corporation is strictly prohibited.



November 25, 2016  
Dwg No: S8082S6 Rev: A (2/16)

FLOMATIC CORPORATION  
GLENS FALLS, N.Y. 12801  
PHONE (518) 761-9797  
FAX (518) 761-9798