

# Air Release Valve

Sizes 1/2" / 15mm

Maxiair®

**FLOMATIC®**  
Flomatic Corporation



## Materials

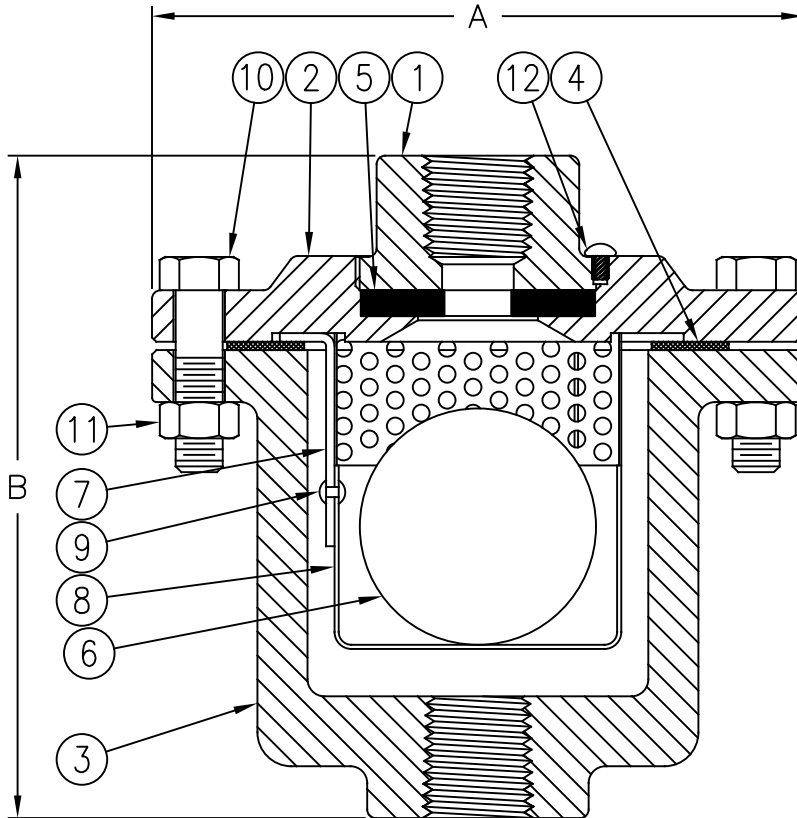

\*Standard operating pressure is:  
minimum 20 psig & maximum 150 psig.  
Consult factory for pressure outside this range.

Item #	Description	Material	ASTM	Item #	Description	Material	ASTM
1	*Top	Cast Iron	A126	7	Hanger	Bronze	B36
2	*Flange	Cast Iron	A126	8	Cup	Bronze	B36
3	*Body	Cast Iron	A126	9	Rivet	Brass	J429
4	Gasket	Armstrong	N-8090	10	Bolt	Steel	J429
5	Seat	Buna-n	-----	11	Nut	Steel	A563
6	Float	Stainless Steel	A240	12	Interference Pin	Stainless Steel	18/8

\* Optional Material Ductile Iron

## Dimensions

Max. Temp 150°F (65C)  
Max. Inlet Pressure 150 psi (10 bar)

Size		Part #	ØA		B		INLET SIZE		OUTLET SIZE		Weight	
inch	mm		inch	mm	inch	mm	inch	mm	inch	mm	lbs	kg
1/2	15	6520	4-3/4	121	5	127	1/2	15	1/2	15	8	4

Meets AWWA C512

Flomatic Corporation can accept no responsibility for possible errors in catalogues, brochures and other printed material. Flomatic Corporation reserves the right to alter its products without notices. This also applies to product already agreed. All trademarks in this material are property of the respective companies. All right reserved. ©2018 Flomatic Corporation. The drawings & information on this drawing sheet are the sole & exclusive property of Flomatic Corporation. Any reproduction, distribution, display or use of these drawings or information in whole or in part without written authorization of Flomatic Corporation is strictly prohibited. [www.flomatic.com](http://www.flomatic.com)

**FLOMATIC® VALVES**

December 30, 1997  
Dwg No: S6520 Rev D (8/18)

FLOMATIC CORPORATION  
GLENS FALLS, N.Y. 12801  
PHONE (518) 761-9797  
FAX (518) 761-9798