

Materials (with Lever)

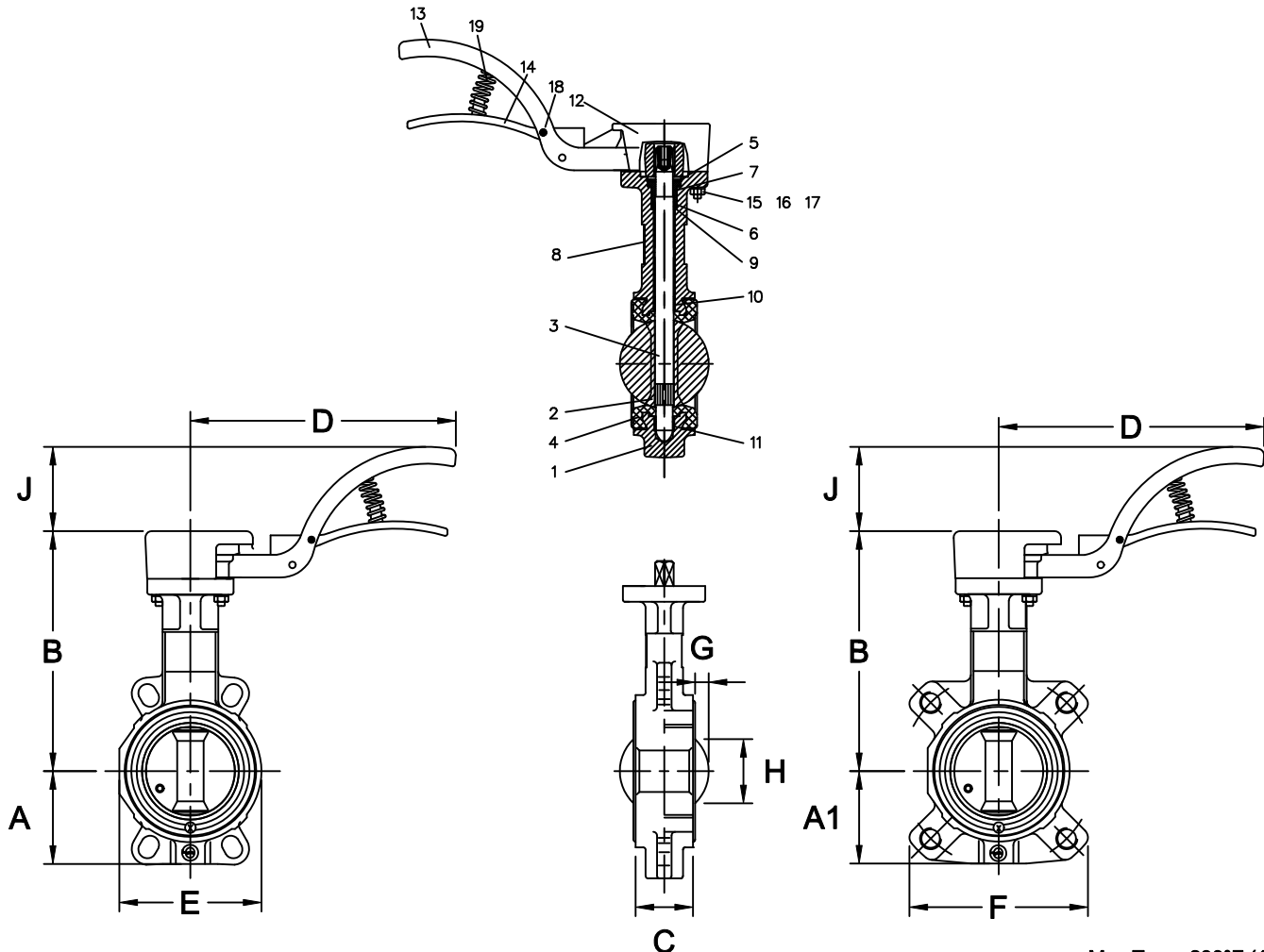

Max Temp 230°F (110°C)
Max Pressure 200psi (14bar)

Item #	Qty	Description	Material	Item #	Qty	Description	Material
1	1	Body	Cast Iron A48	11	1	Lower Guide Bushing	Zinc Coated Steel + PTFE
2	1	Disc	Ductile Iron A536 or 316 SS	12	1	Cap	Ductile Iron A536/Cast Iron A48
3	1	Shaft	AISI 420	13	1	Hand Lever	Ductile Iron A536
4	1	Liner	EPDM	14	1	Lever	Ductile Iron A536
5	1	Circlip	Steel XC 75/Stainless Steel	15	2	CHc Screw	Zinc Coated Steel
6	1	O'Ring	Nitrile	16	2	Stop Washer	Zinc Coated Steel
7	1	Bushing	IXEF	17	1	Nut	Zinc Coated Steel
8	1	Metal Tag	Aluminium	18	1	Pin	Stainless Steel
9	1	Safety Bushing	304L SS	19	1	Spring	Stainless Steel
10	1	Upper Guide Bushing	Zinc Coated Steel + PTFE				

Flomatic Corporation can accept no responsibility for possible errors in catalogues, brochures and other printed material. Flomatic Corporation reserves the right to alter its products without notices. This also applies to product already agreed. All trademarks in this material are property of the respective companies. All right reserved. ©2011 Flomatic Corporation. The drawings & information on this drawing sheet are the sole & exclusive property of Flomatic Corporation. Any reproduction, distribution, display or use of these drawings or information in whole or in part without written authorization of Flomatic Corporation is strictly prohibited.

Butterfly Valves

Sylax[®] 2

Model 149G



Sizes 2" Thru 6" / 50 mm Thru 150 mm

Dimensions



Size		A		B		C		D		E		F		G		H		J	
inch	mm	inch	mm	inch	mm	inch	mm	inch	mm	inch	mm	inch	mm	inch	mm	inch	mm	inch	mm
2	50	2.44	62	6.65	169	1.69	43	7.87	200	4.76	121	4.76	121	.24	6	1.29	33	1.77	45
2-1/2	65	3.31	84	7.01	178	1.81	46	7.87	200	5.35	136	5.31	135	.52	13	2.17	55	1.77	45
3	80	3.51	89	7.24	184	1.81	46	7.87	200	5.00	127	7.05	179	.79	20	2.87	73	1.77	45
4	100	4.17	106	8.19	208	2.05	52	11.42	290	5.87	149	8.11	206	.98	25	3.43	87	1.77	45
6	150	5.16	131	9.29	236	2.20	56	11.42	290	5.87	209	8.23	265	1.89	48	5.55	141	2.56	65

Size		A1		Wgt Lug		Wgt Wafer	
inch	mm	inch	mm	lbs	kg	lbs	kg
2	50	2.44	62	8.4	3.8	7.5	3.4
2-1/2	65	2.76	70	9.1	4.1	8.2	3.7
3	80	3.51	89	11.1	5.0	9.7	4.4
4	100	4.06	103	15.9	7.2	12.3	5.6
6	150	5.16	131	27.4	12.4	18.3	8.3

Flomatic Corporation can accept no responsibility for possible errors in catalogues, brochures and other printed material. Flomatic Corporation reserves the right to alter its products without notices. This also applies to product already agreed. All trademarks in this material are property of the respective companies. All right reserved. ©2011 Flomatic Corporation. The drawings & information on this drawing sheet are the sole & exclusive property of Flomatic Corporation. Any reproduction, distribution, display or use of these drawings or information in whole or in part without written authorization of Flomatic Corporation is strictly prohibited.

