

Materials (with Lever & Buna-N Seat)

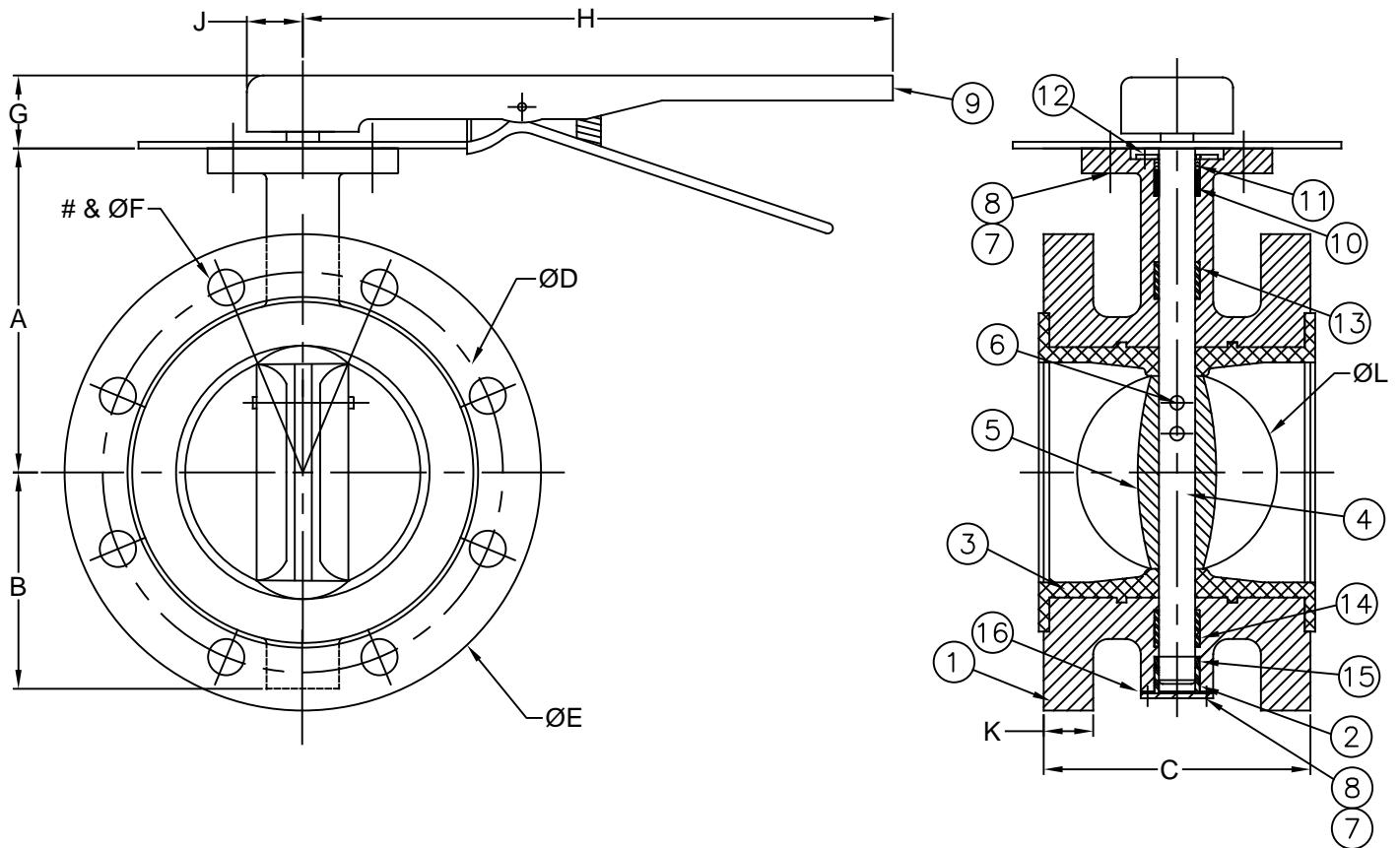

Item #	Description	Material	Item #	Description	Material
1	Body	Ductile Iron A536	9	Lever	Cast Iron
2	Lower Hole Gasket	Nylon	10	Packing V-Type	Buna-N
3	Seat*	Buna-N	11	Lower Hole Gasket	Stainless Steel
4	Shaft	316SS	12	Garter Spring	AISI 1066
5	Disc	Ductile Iron w/316SS Edge	13	Upper Bushing	304SS
6	Pin/Nut/Wahser/O-Ring	304SS/Rubber	14	Lower Bushing	304SS
7	Bolts	Stainless Steel	15	Combined Ring	Buna-N
8	Washer	Stainless Steel	16	Bottom Cover Gasket	Buna-N

Max Temp 180°F (82°C)
Max Pressure 200psi (14bar)
Max Pressure Differential 150psi (10bar)
* EPDM Optional

Flomatic Corporation can accept no responsibility for possible errors in catalogues, brochures and other printed material. Flomatic Corporation reserves the right to alter its products without notices. This also applies to product already agreed. All trademarks in this material are property of the respective companies. All right reserved. ©2017 Flomatic Corporation. The drawings & information on this drawing sheet are the sole & exclusive property of Flomatic Corporation. Any reproduction, distribution, display or use of these drawings or information in whole or in part without written authorization of Flomatic Corporation is strictly prohibited.

Dimensions



Size		Part #	A		B		C		ØD		ØE		# & ØF	
inch	mm		inch	mm	inch	mm	inch	mm	inch	mm	inch	mm	inch	mm
3	80	450000061	6.25	159	3.54	90	5.00	127	6.0	152	7.50	190	4-.75	19
4	100	450000071	7.00	178	3.98	101	5.00	127	7.5	191	9.06	230	8-.75	19
6	150	450000091	8.00	203	5.87	149	5.00	127	9.5	241	11.00	280	8-.88	22

Size		G		H		J		K		ØL		Weight	
inch	mm	inch	mm	inch	mm	inch	mm	inch	mm	inch	mm	lbs	kg
3	80	1.57	40	10.24	260	.98	25	.75	19	2.93	74.6	27	12.2
4	100	1.57	40	10.24	260	.98	25	.94	24	3.71	94.3	39	17.7
6	150	2.05	52	17.72	450	1.50	38	1.00	25	5.63	142.9	65	29.4

Flomatic Corporation can accept no responsibility for possible errors in catalogues, brochures and other printed material. Flomatic Corporation reserves the right to alter its products without notices. This also applies to product already agreed. All trademarks in this material are property of the respective companies. All right reserved. ©2017 Flomatic Corporation. The drawings & information on this drawing sheet are the sole & exclusive property of Flomatic Corporation. Any reproduction, distribution, display or use of these drawings or information in whole or in part without written authorization of Flomatic Corporation is strictly prohibited.