

Butterfly Valve Wafer with Actuator

Sizes 2" Thru 12"/ 50 mm Thru 300 mm

Sylax® 3 **FLOMATIC®**

Flomatic Corporation



Materials

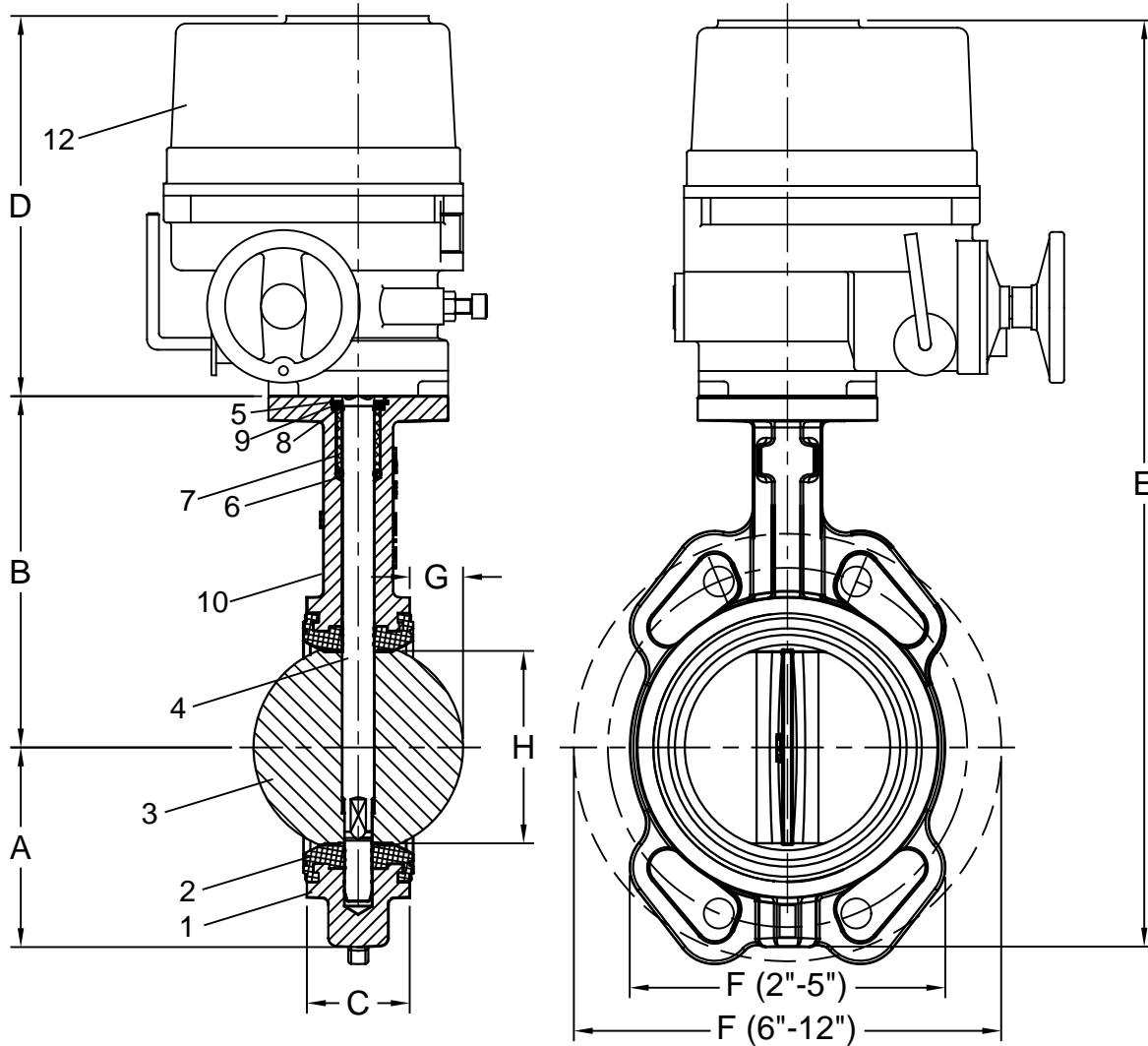

Max Temp 220°F (104°C)
Max Pressure 250psi (17bar)

Bi-Directional & Dead End Service Pressure Rating 250psi (17 bar)

Item #	Qty	Description	Material	Item #	Qty	Description	Material
1	1	Body	Ductile Iron A536 65-45-12	7	1	Bushing	Nylon 1010
2	1	Seat	EPDM	8	1	Circlip	Steel XC 75/Stainless Steel
3	1	Disc	Stainless Steel 316	9	1	Washer	Stainless Steel 304
4	1	Stem	Stainless Steel 420	10	1	Metal Tag	Aluminium
5	1	Circlip	Steel XC 75/Stainless Steel	11	1	Actuator*	Details on Spec Sheet SRCEL
6	1	O'Ring	NBR				

***Actuators are sized @ 145 psi ΔP and 50% safety factor**

Flomatic Corporation can accept no responsibility for possible errors in catalogues, brochures and other printed material. Flomatic Corporation reserves the right to alter its products without notices. This also applies to product already agreed. All trademarks in this material are property of the respective companies. All right reserved. ©2018 Flomatic Corporation. The drawings & information on this drawing sheet are the sole & exclusive property of Flomatic Corporation. Any reproduction, distribution, display or use of these drawings or information in whole or in part without written authorization of Flomatic Corporation is strictly prohibited. www.flomatic.com

Butterfly Valves

Wafer with Actuator

Sylax® 3 **FLOMATIC**

Flomatic Corporation

Sizes 2" Thru 12"/ 50 mm Thru 300 mm



Dimensions

ASME B16.5 150# Flange / ISO 5211 Top Flange

Size		Part #	A		B		C		D		E		F*		G		H		Actuator #	Wgt Lug	
inch	mm		inch	mm	inch	mm	inch	mm	inch	mm	inch	mm	inch	mm	inch	mm	inch	mm		lbs	kg
2	50	S3W04A	2.5	65	5.67	141	1.69	43	10.75	273	18.80	273	5.15	131	.21	5	2.12	54	FCEL-9ALS	32	14
2-1/2	65	S3W05A	2.8	72	6.02	153	1.81	46	10.75	273	19.57	273	5.66	144	.38	10	2.57	65	FCEL-9ALS	32	14
3	80	S3W06A	3.4	86	6.22	158	1.81	46	10.75	273	20.37	273	5.86	149	.66	17	3.14	80	FCEL-9ALS	33	15
4	100	S3W07A	3.9	100	7	178	2.05	52	10.75	273	21.58	273	6.27	159	1.04	27	4.14	105	FCEL-9ALS	37	17
5	125	S3W08A	4.4	112	7.52	191	2.20	56	10.75	273	22.67	273	7.17	182	1.46	37	5.13	130	FCEL-9ALS	41	19
6	150	S3W09A	5.0	128	7.97	203	2.20	56	10.75	273	23.72	273	8.36	212	1.97	50	6.14	156	FCEL-15ALS	45	20
8	200	S3W10A	6.4	162	9.59	244	2.36	60	12.60	320	28.59	125	10.50	267	2.95	75	8.14	207	FCEL-28ALS	98	45
10	250	S3W11A	7.6	194	10.75	273	2.68	68	12.60	320	30.95	125	12.66	322	3.70	94	9.97	253	FCEL-50ALS	115	52
12	300	S3W12A	8.8	223	12.24	311	3.07	78	14.21	361	35.25	895	14.72	374	4.46	113	11.90	302	FCEL-60ALS	149	68

F* - 6" THRU 12" BODY IS WIDER THAN THE BOLT LUGS - SEE SPEC SS3W04

Flomatic Corporation can accept no responsibility for possible errors in catalogues, brochures and other printed material. Flomatic Corporation reserves the right to alter its products without notices. This also applies to product already agreed. All trademarks in this material are property of the respective companies. All right reserved. ©2018 Flomatic Corporation. The drawings & information on this drawing sheet are the sole & exclusive property of Flomatic Corporation. Any reproduction, distribution, display or use of these drawings or information in whole or in part without written authorization of Flomatic Corporation is strictly prohibited. www.flomatic.com