

Ball Check Valve

Sizes 3" Thru 12" / 80 mm Thru 300 mm
Lay Length Comparison

Model 408 vs. 408² **FLOMATIC**
Flomatic Corporation

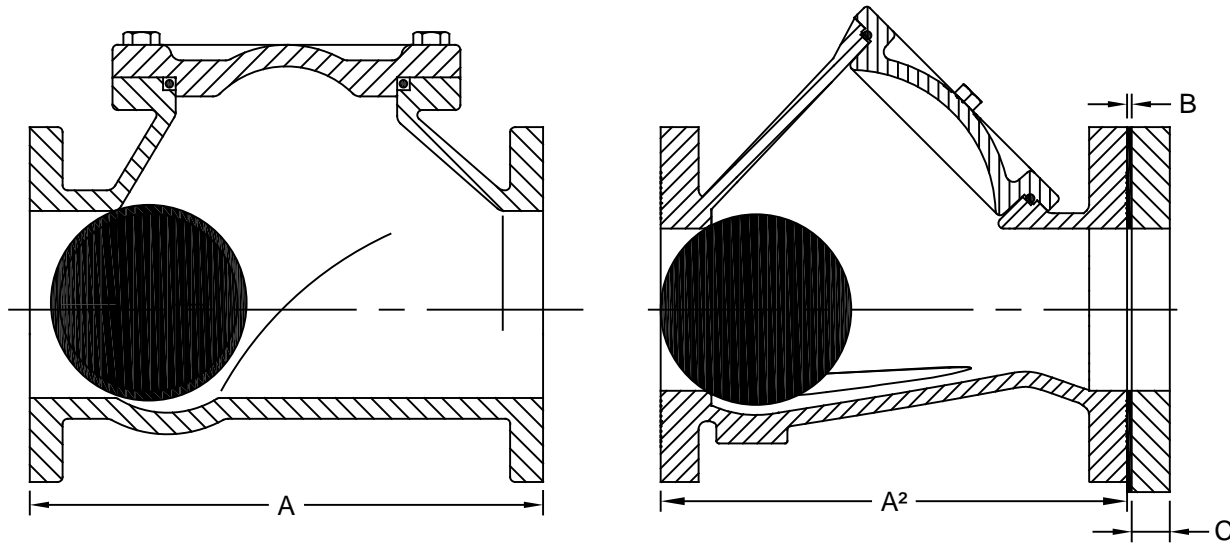

Size (Inch)	408 (A)	408 ² (A ²)	Difference (A-A ²)	Gasket Thickness (B)	Spacer Thickness Needed (C)	OD of Spacer	ID of Spacer
3	10.25	9.5	.75	.0625	.6875	7.5	3
4	12.1875	11.5	.6875	.0625	.625	9.0	4
6	16.0625	14.0	2.0625	.0625	2.0	11.0	6
8	19.6875	19.5	.1875	.0625	.125	13.5	8
10	23.625	24.5	-.875	.0625	N/A	N/A	N/A
12	27.5469	27.5	.0469	.0625	N/A	N/A	N/A

Flomatic Corporation can accept no responsibility for possible errors in catalogues, brochures and other printed material. Flomatic Corporation reserves the right to alter its products without notices. This also applies to product already agreed. All trademarks in this material are property of the respective companies. All rights reserved. ©2019 Flomatic Corporation. The drawings & information on this drawing sheet are the sole & exclusive property of Flomatic Corporation. Any reproduction, distribution, display or use of these drawings or information in whole or in part without written authorization of Flomatic Corporation is strictly prohibited. www.flomatic.com