

Submersible Pump Check Valve

Model 80MDW-VFD **FLOMATIC®**

Sizes 9-5/8" / 245mm
8 Round Short x Long Casing Threads

Flomatic Corporation



Materials

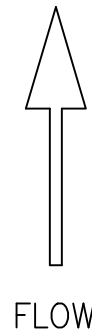
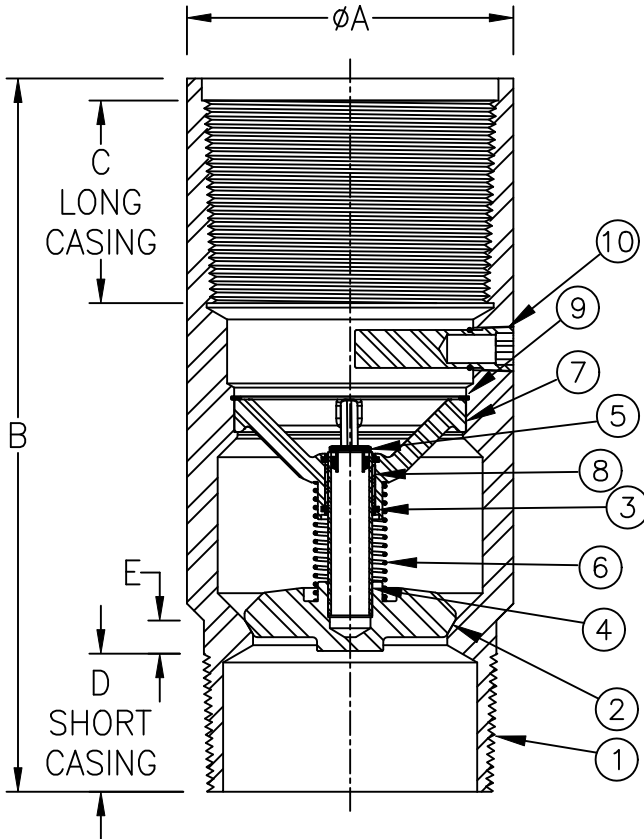

Max Temp 200°F (93°C)
Max Pressure 4400psi (303bar)

Item #	Qty	Description	Material	ASTM
1	1	Body (Epoxy Coated*)	Hot Rolled Steel	A519
2	1	Poppet	Hot Rolled Steel	A332
3	2	Wiper	Engineered Composite	-----
4	1	Stem	Stainless Steel	316
5	1	Stem Cap	Engineered Composite	-----
6	1	Spring	Stainless Steel	304
7	1	Stem Guide	Stainless Steel	316
8	1	Bushing	Engineered Composite	-----
9	1	Retaining Ring	Stainless Steel	302
10	1	3/4" Break-Off Plug	Stainless Steel	304

Epoxy Coating is NSF61 approved

Dimensions (M short casing x F long casing)

Thread Size		Part #	A		B		C		D		E		Weight	
Inch	mm		Inch	mm	Inch	mm	Inch	mm	Inch	mm	Inch	mm	lbs	kg
9-5/8	245	4093MDW8SLPLG	10-5/8	270	19-3/8	492	5-1/16	129	3-3/8	86	3/4	19	154	70

Flomatic Corporation can accept no responsibility for possible errors in catalogues, brochures and other printed material. Flomatic Corporation reserves the right to alter its products without notices. This also applies to product already agreed. All trademarks in this material are property of the respective companies. All right reserved. ©2011 Flomatic Corporation. The drawings & information on this drawing sheet are the sole & exclusive property of Flomatic Corporation. Any reproduction, distribution, display or use of these drawings or information in whole or in part without written authorization of Flomatic Corporation is strictly prohibited.