

Materials

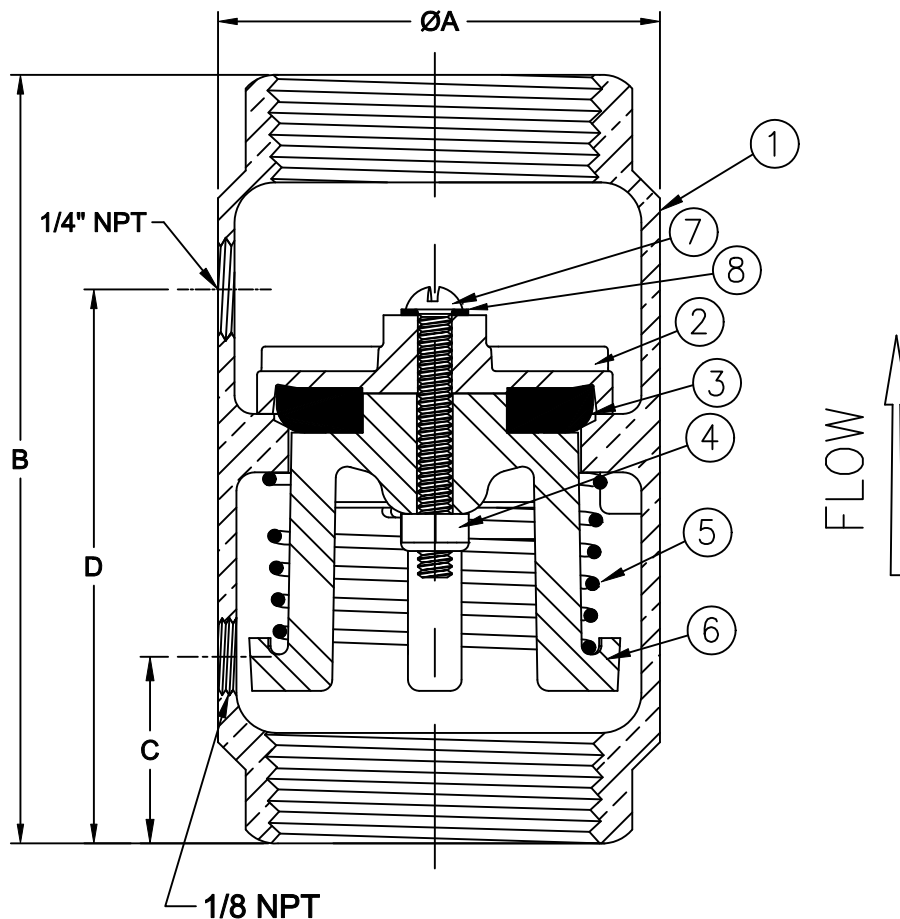

Temp Max: 180°F (82°C)
Pressure Max: 400 psi (28 bar)

Item #	Qty	Description	Material	ASTM	Item #	Qty	Description	Material	ASTM
1	1	Body	Unleaded Bronze	C89833	5	1	Spring	Stainless Steel	303
2	1	Dome	Stainless Steel	304	6	1	Guide	Delrin	----
3	1	Disc*	Buna-n	-----	7	1	Screw	Stainless Steel	18-8
4	1	Nut	Stainless Steel	304	8	1	Washer	Nylon	----

*Optional Viton available

Dimensions

Size		Part #	A		B		C		D		Weight	
inch	mm		inch	mm	inch	mm	inch	mm	inch	mm	lbs	kg
2	50	4054E	3	76	5-1/4	133	1-1/32	26	4-7/32	107	3-7/64	1.4

Flomatic Corporation can accept no responsibility for possible errors in catalogues, brochures and other printed material. Flomatic Corporation reserves the right to alter its products without notices. This also applies to product already agreed. All trademarks in this material are property of the respective companies. All right reserved. ©2011 Flomatic Corporation. The drawings & information on this drawing sheet are the sole & exclusive property of Flomatic Corporation. Any reproduction, distribution, display or use of these drawings or information in whole or in part without written authorization of Flomatic Corporation is strictly prohibited.

Materials

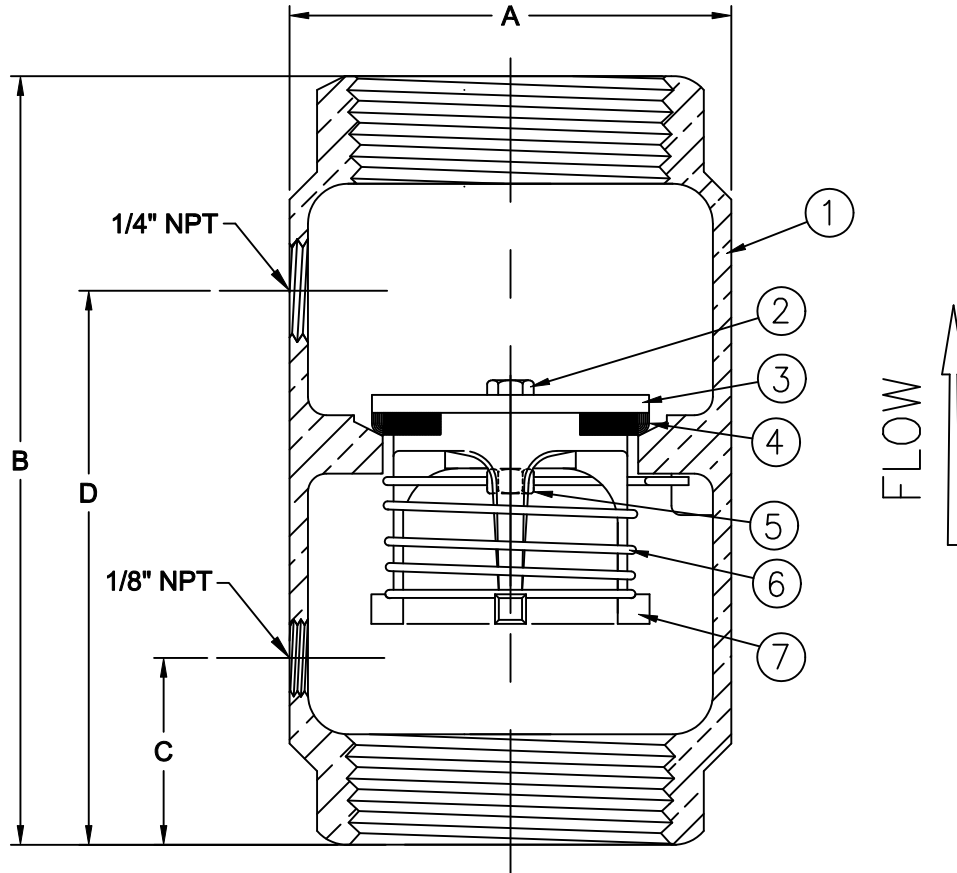

Temp Max: 180°F (82°C)
Pressure Max: 400 psi (28 bar)

Item #	Qty	Description	Material	ASTM	Item #	Qty	Description	Material	ASTM
1	1	Body	Unleaded Bronze	C89833	5	1	Nut	Stainless Steel	18-8
2	1	Bolt	Stainless Steel	18-8	6	1	Spring	Stainless Steel	302
3	1	Washer	Stainless Steel	18-8	7	1	Guide*	Unleaded Bronze	C89833
4	1	Disc**	Buna-n	-----	*Guide for 4" is 316 Stainless Steel **Optional Viton available				

Dimensions

Size		Part #	A		B		C		D		Weight	
inch	mm		inch	mm	inch	mm	inch	mm	inch	mm	lbs	kg
2-1/2	65	4055E	3-11/16	94	6-1/16	154	1-5/16	33	4-11/16	119	6-1/2	3
3	80	4056E	4-17/32	115	7	178	1-9/16	40	5-17/32	140	13	5.9
4	100	4057E	5-3/4	146	8-1/4	210	1-3/4	44	6-1/2	165	24	10.9

Fromatic Corporation can accept no responsibility for possible errors in catalogues, brochures and other printed material. Fromatic Corporation reserves the right to alter its products without notices. This also applies to product already agreed. All trademarks in this material are property of the respective companies. All right reserved. ©2011 Fromatic Corporation. The drawings & information on this drawing sheet are the sole & exclusive property of Fromatic Corporation. Any reproduction, distribution, display or use of these drawings or information in whole or in part without written authorization of Fromatic Corporation is strictly prohibited.