

Materials

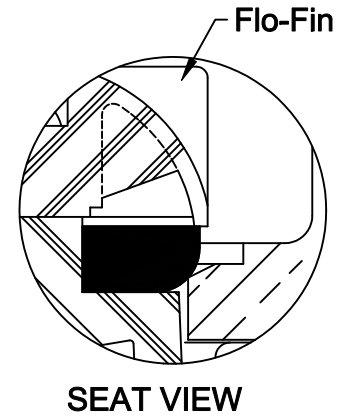
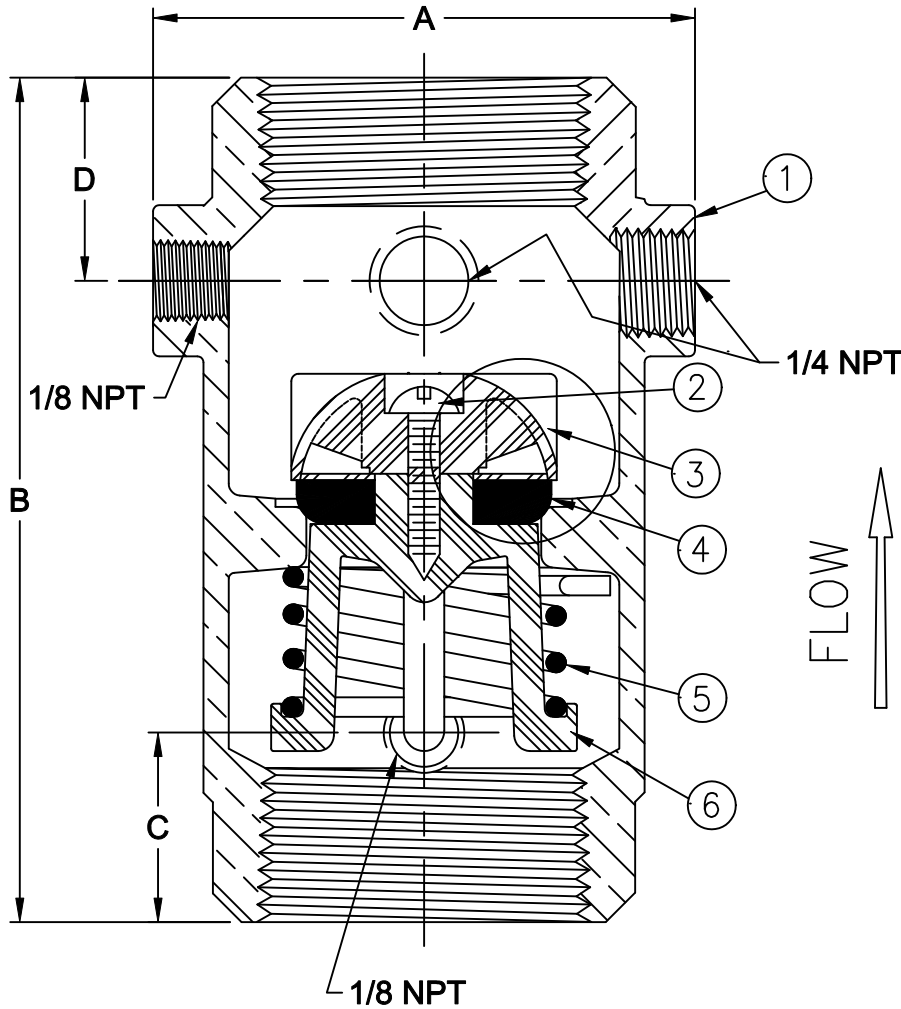

Temp Max: 180°F
Pressure Max: 400 psi

Item #	Qty	Description	Material	ASTM
1	1	Body	Unleaded Bronze	C89833
2	1	Screw	Stainless Steel	18-8
3	1	Dome	Delrin	-----
4	1	Disc	Buna-n	-----
5	1	Spring	Stainless Steel	18-8
6	1	Guide	Delrin	-----

*1/8" NPT PIPE PLUG INCLUDED

Patent # 4,971,093 & 6,581,633

Dimensions

Size		Part #	A		B		C		D		Weight	
inch	mm		inch	mm	inch	mm	inch	mm	inch	mm	lbs	kg
1	25	4061E	1-29/32	48	3-3/4	95	15/16	24	15/16	24	1-13/64	.55
1-1/4	32	4062E	2-11/16	68	4-3/16	106	15/16	24	1	25	1-13/16	.82
1-1/2	40	4063E	3	76	4-5/8	117	1-1/32	26	1-1/8	29	2-11/16	1.22

Fromatic Corporation can accept no responsibility for possible errors in catalogues, brochures and other printed material. Fromatic Corporation reserves the right to alter its products without notices. This also applies to product already agreed. All trademarks in this material are property of the respective companies. All right reserved. ©2011 Fromatic Corporation. The drawings & information on this drawing sheet are the sole & exclusive property of Fromatic Corporation. Any reproduction, distribution, display or use of these drawings or information in whole or in part without written authorization of Fromatic Corporation is strictly prohibited.