

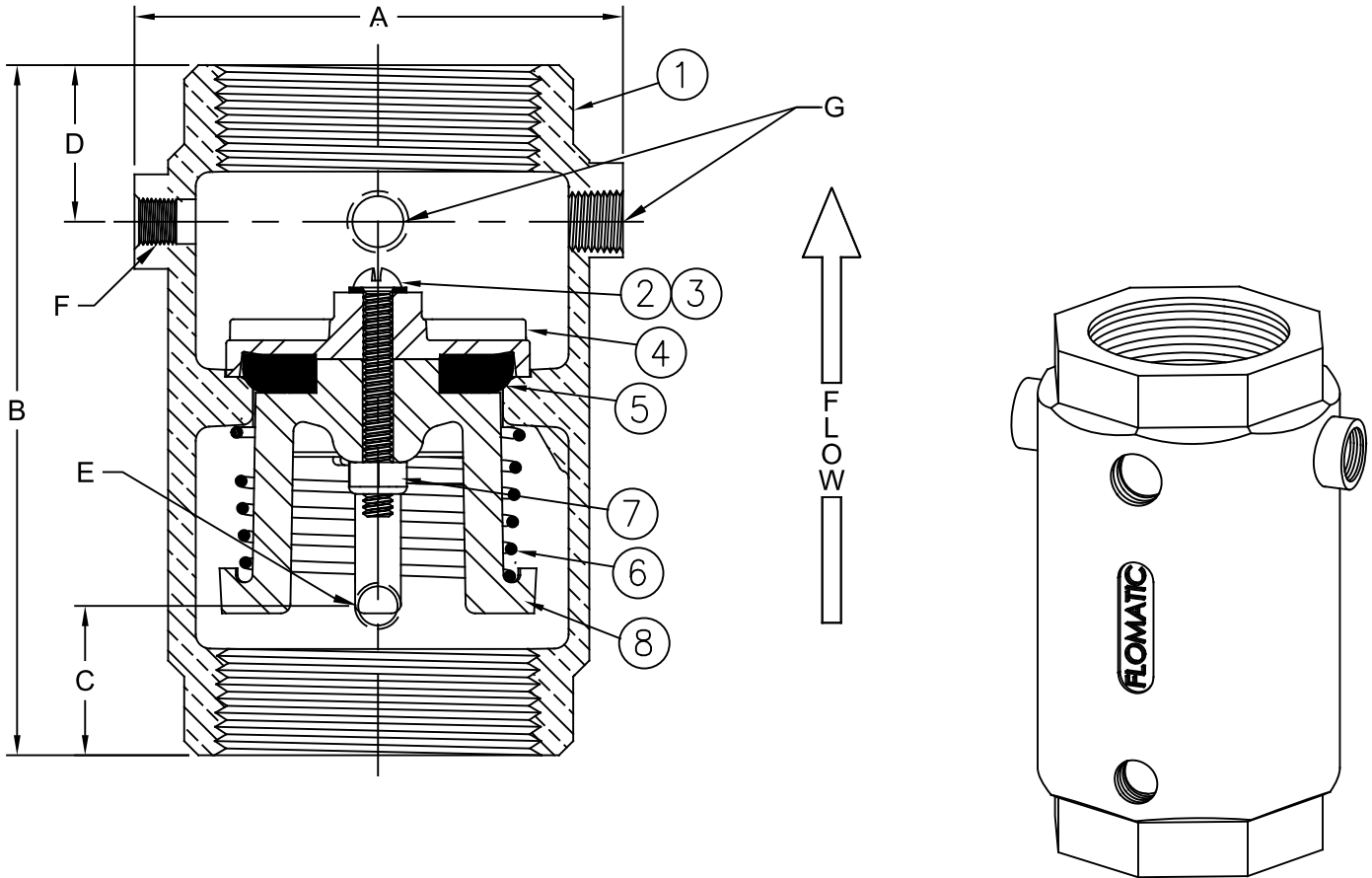

Materials



Temp Max: 180°F (82°C)
Pressure Max: 400 psi (28 bar)

Item #	Qty	Description	Material	ASTM	Item #	Qty	Description	Material	ASTM
1	1	Body	Unleaded Bronze	C89833	5	1	Disc	Buna	N-5007
2	1	Screw	Stainless Steel	18-8	6	1	Spring	Stainless Steel	302
3	1	Washer	Nylon	----	7	1	Nut	SS / Nylon	304
4	1	Dome	Stainless Steel	304	8	1	Guide	Celcon®	M90

1/8" Pipe Plug Included

Dimensions (FNPT X FNPT)

ANSI B1.20.1

Size		Part #	A		B		C		D		E	F	G	Weight	
inch	mm		inch	mm	inch	mm	inch	mm	inch	mm	NPT	NPT	NPT	lbs	kg
2	50	4064E	3.50	89	5.28	134	1.03	26	1.07	27	1/8	1/8	1/4	3.80	1.7

Flomatic Corporation can accept no responsibility for possible errors in catalogues, brochures and other printed material. Flomatic Corporation reserves the right to alter its products without notices. This also applies to product already agreed. All trademarks in this material are property of the respective companies. All rights reserved. ©2024 Flomatic Corporation. The drawings & information on this drawing sheet are the sole & exclusive property of Flomatic Corporation. Any reproduction, distribution, display or use of these drawings or information in whole or in part without written authorization of Flomatic Corporation is strictly prohibited. www.flomatic.com