

Materials

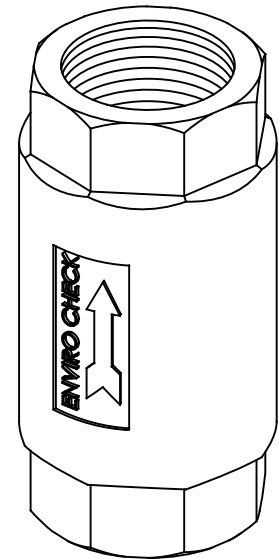
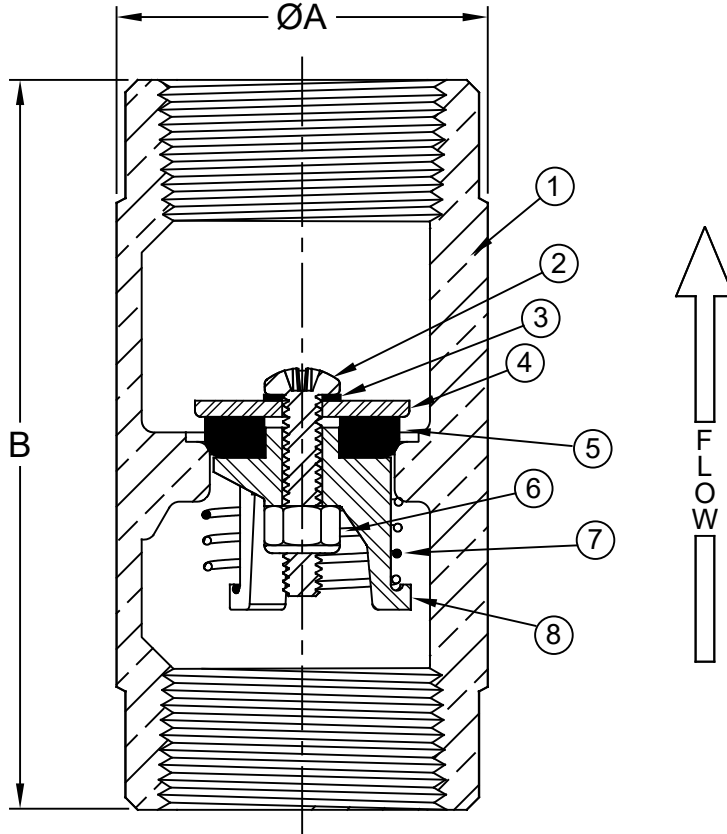
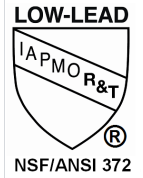

Temp Max: 400°F (204°C)
Pressure Max: 100 psi (6.8 bar)

Item #	Qty	Description	Material	ASTM	Item #	Qty	Description	Material	ASTM
1	1	Body	Unleaded Bronze	C89833	5	1	Disc	Viton	80FC2181
2	1	Screw	Stainless Steel	316	6	1	Nut	Stainless Steel/Nylon	304/N200SL
3	1	Washer	Nylon	42A NCO10	7	1	Spring	Stainless Steel	302
4	1	Washer	Stainless Steel	304	8	1	Guide	Stainless Steel	316

Dimensions (FNPT x FNPT)

Patent #'s 4,971,093 & 6,581,633

ANSI B1.20.1

Size		Part #	A		B		Weight	
inch	mm		inch	mm	inch	mm	lbs	kg
1	25	4031HTE	1.84	48	3.63	92	1.25	.58

Flomatic Corporation can accept no responsibility for possible errors in catalogues, brochures and other printed material. Flomatic Corporation reserves the right to alter its products without notices. This also applies to product already agreed. All trademarks in this material are property of the respective companies. All rights reserved. ©2021 Flomatic Corporation. The drawings & information on this drawing sheet are the sole & exclusive property of Flomatic Corporation. Any reproduction, distribution, display or use of these drawings or information in whole or in part without written authorization of Flomatic Corporation is strictly prohibited. www.flomatic.com