

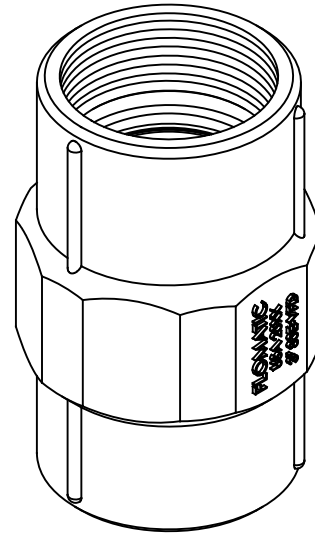

Materials

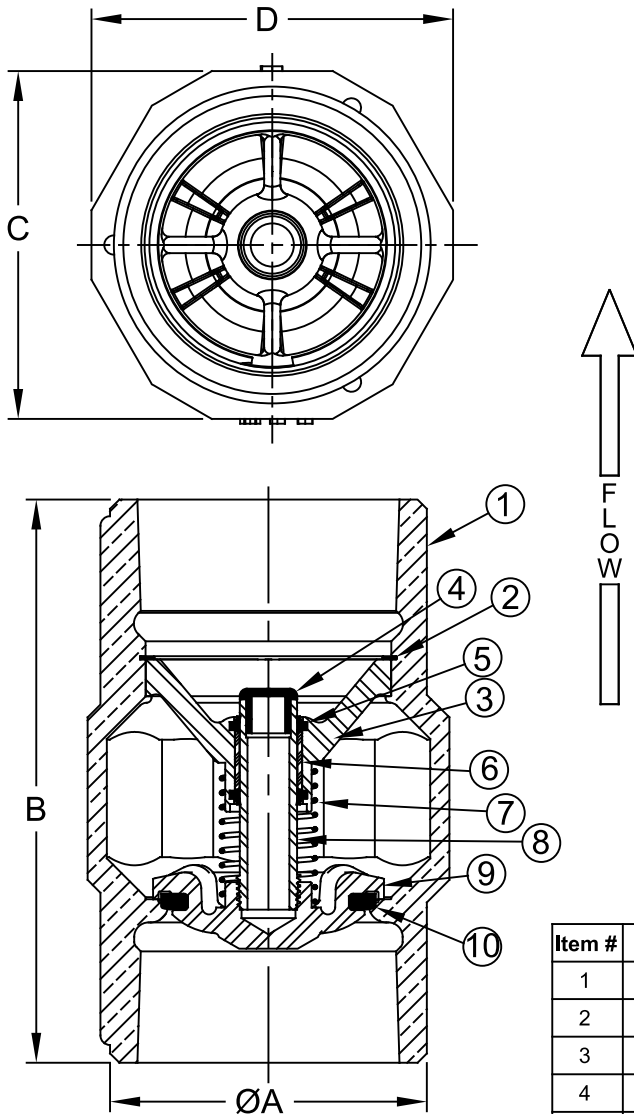

Max Temp 180°F (82°C)
Max Pressure 400psi (28bar)

Item #	Qty	Description	Material	ASTM
1	1	Body	Unleaded Bronze	C89833
2	1	Retaining Ring	Stainless Steel	302
3	1	Stem Guide	Stainless Steel	316
4	1	Stem Cap	Engineered Composite	Polyethylene
5	2	Wiper	Engineered Composite	Molythane
6	1	Bushing	Engineered Composite	-----
7	1	Spring	Stainless Steel	302
8	1	Stem	Stainless Steel	316
9	1	Disc	Buna-N	N-5007*
10	1	Poppet	Stainless Steel	316

Dimensions (FNPT x FNPT)

Patent # 9,032,992

ANSI B1.20.1

Size		Part #	A		B		C		D		Weight	
inch	mm		inch	mm	inch	mm	inch	mm	inch	mm	lbs	kg
3	75	4036EVFD	4-1/8	77	7-21/64	126	4-17/32	68	4-45/64	68	12	5.5
4	100	4037EVFD	5-9/32	77	9-3/16	126	5-3/4	68	6	68	23	10.4

Flomatic Corporation can accept no responsibility for possible errors in catalogues, brochures and other printed material. Flomatic Corporation reserves the right to alter its products without notices. This also applies to product already agreed. All trademarks in this material are property of the respective companies. All rights reserved. ©2021 Flomatic Corporation. The drawings & information on this drawing sheet are the sole & exclusive property of Flomatic Corporation. Any reproduction, distribution, display or use of these drawings or information in whole or in part without written authorization of Flomatic Corporation is strictly prohibited. www.flomatic.com