

Enviro® Check Valve

Model 80XBEVFD



Flomatic Corporation

Sizes 1" / 25 mm
Double Tap

Materials

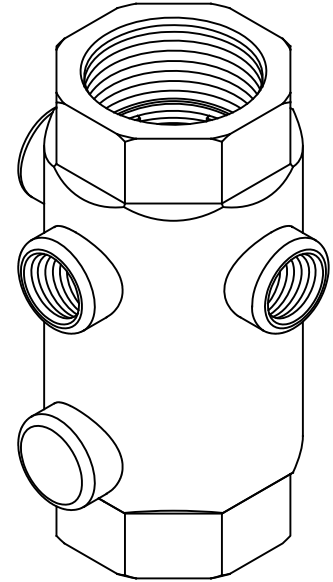
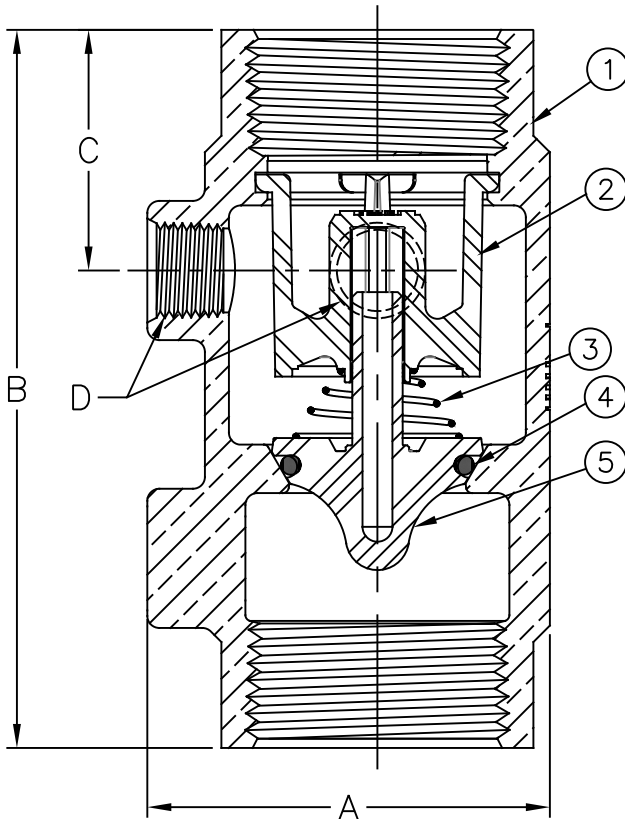
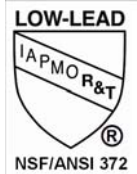
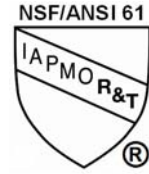

Max Temp 180°F (82°C)
Max Pressure 400 psi (28bar)

Item #	Qty	Description	Material	ASTM	Item #	Qty	Description	Material	ASTM
1	1	Body	Unleaded Bronze	C89833	4	1	O-Ring	Buna-n	-----
2	1	Guide	Delrin	100 Black	5	1	Poppet*	Delrin	100 Black
3	1	Spring	Stainless Steel	302	*Optional SS add an S between E & VFD				

Dimensions (FNPT)

Patent # 8,978,696

Size		Part #	A		B		C		D (Outlet NPT)	Weight	
inch	mm		inch	mm	inch	mm	inch	mm	inch	lbs	kg
1	25	7961EVFD	2-3/32	53	3-3/4	95	1-1/4	32	1/4	1-3/16	.54

Flomatic Corporation can accept no responsibility for possible errors in catalogues, brochures and other printed material. Flomatic Corporation reserves the right to alter its products without notices. This also applies to product already agreed. All trademarks in this material are property of the respective companies. All right reserved. ©2018 Flomatic Corporation. The drawings & information on this drawing sheet are the sole & exclusive property of Flomatic Corporation. Any reproduction, distribution, display or use of these drawings or information in whole or in part without written authorization of Flomatic Corporation is strictly prohibited.



April 18, 2017
Dwg No: S7961EVFD Rev: A (1/18)

FLOMATIC CORPORATION
GLENS FALLS, N.Y. 12801
PHONE (518) 761-9797
FAX (518) 761-9798