

Ductile Iron Check Valve

Model 80DI



Flomatic Corporation

Sizes 2-1/2" / 65 mm

LEAD FREE
NSF/ANSI 61



Materials

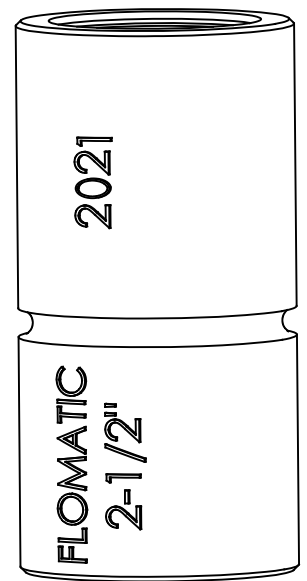
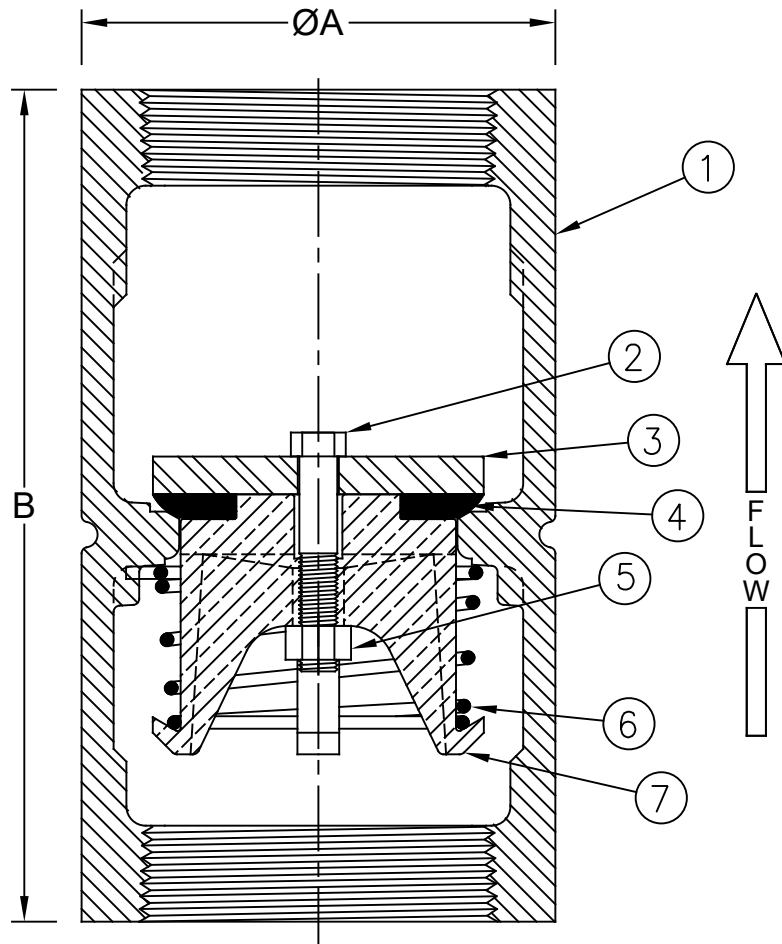

Max Temp 180°F (82°C)
Max Pressure 600psi (42bar)

Item #	Qty	Description	Material	ASTM
1	1	Body (Epoxy Coated)	Ductile Iron	65-45-12
2	1	Bolt	Stainless Steel	304
3	1	Washer	Stainless Steel	304
4	1	Rubber Disc	Buna-n	N-5007
5	1	Nut	Stainless Steel	304
6	1	Spring	Stainless Steel	302
7	1	Guide	Bronze	C89833

Dimensions (FNPT X FNPT)

ANSI B1.20.1

Size		Part #	A		B		Weight	
inch	mm		inch	mm	inch	mm	lbs	kg
2-1/2	65	7936	3-5/8	92	7-3/16	183	8.5	4

Flomatic Corporation can accept no responsibility for possible errors in catalogues, brochures and other printed material. Flomatic Corporation reserves the right to alter its products without notices. This also applies to product already agreed. All trademarks in this material are property of the respective companies. All rights reserved. ©2024 Flomatic Corporation. The drawings & information on this drawing sheet are the sole & exclusive property of Flomatic Corporation. Any reproduction, distribution, display or use of these drawings or information in whole or in part without written authorization of Flomatic Corporation is strictly prohibited. www.flomatic.com



January 25, 2005
Dwg No: S7936 Rev: G (1/24)

FLOMATIC CORPORATION
GLENS FALLS, N.Y. 12801
PHONE (518) 761-9797
FAX (518) 761-9798