

Break-Off Plug

Submersible Pump Valves



Sizes 2" thru 12"/ 50 mm thru 300 mm



Instructions:

- A. Drop a length of pipe (see chart) down the riser pipe.
- B. The break-off plug breaks allowing the riser pipe to drain.

Benefits:

- A. Reduces the lifting weight. By 25% to 50%
- B. Eliminates water splashing at the surface.



- C. Simply replace the Break-Off Plug for re-installation. **WARNING: Break-Off Plug MUST BE INSTALLED WITH TEFLON TAPE**

Features:

- A. No corrosive parts (304 Stainless Steel or NSF Approved Glass Filled Nylon)
- B. Available in all submersible pump check valves (80DI, DIX, VFD & 82DI series) from 2" thru 12".

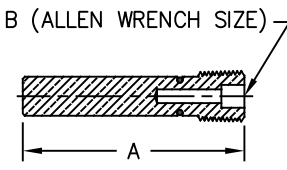
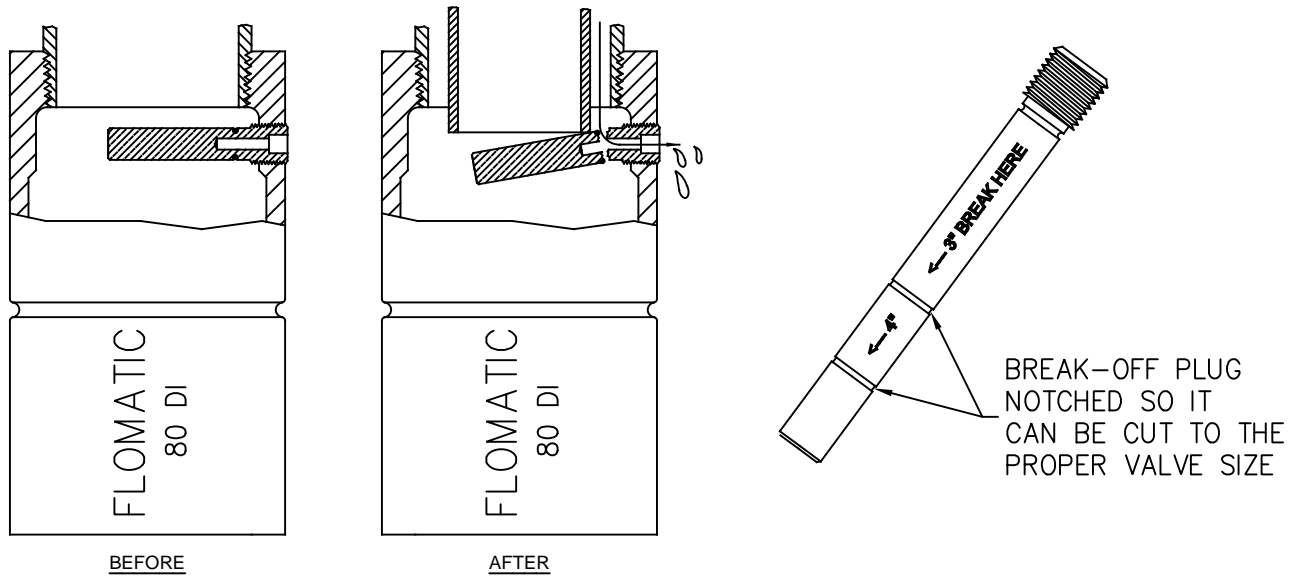

Valve Size		Part # 304 Stainless Steel	Part # Nylon	NPT Size	A		B		Break-Off Pipe			
inch	mm				inch	mm	inch	mm	Size		Length	
					inch	mm	inch	mm	inch	mm	feet	meters
2	50	76098-2	N/A	1/8	2	50	7/32	6	1"	25	10	3
2-1/2	65	76098-3	76098P	3/8	2-1/2	65	5/16	8	1-1/2	40	10	3
3	75	76098-6	76098P	3/8	3	75	5/16	8	1-1/2	40	10	3
4	100	76098-7	76098P	3/8	4	100	5/16	8	2	50	10	3
5	125	76098	76098P	3/8	5	125	5/16	8	2-1/2	65	10	3
6	150	76098	76098P	3/8	5	125	5/16	8	3	80	4	1.2
8	200	76098	76098P	3/8	5	125	5/16	8	4	100	4	1.2
8	200	76098-8	N/A	1/2	5	125	1/2	50	4	100	4	1.2
10	250	76098-11	N/A	1/2	8-1/2	206	1/2	50	5	125	4	1.2
12	300	76098-11	N/A	1/2	8-1/2	206	1/2	50	5	125	4	1.2

Flomatic Corporation can accept no responsibility for possible errors in catalogues, brochures and other printed material. Flomatic Corporation reserves the right to alter its products without notices. This also applies to product already agreed. All trademarks in this material are property of the respective companies. All rights reserved. ©2019 Flomatic Corporation. The drawings & information on this drawing sheet are the sole & exclusive property of Flomatic Corporation. Any reproduction, distribution, display or use of these drawings or information in whole or in part without written authorization of Flomatic Corporation is strictly prohibited. www.flomatic.com



January 30, 1995
Dwg No:S80DIPLG Rev P (12/19)

FLOMATIC CORPORATION
GLENS FALLS, N.Y. 12801
PHONE (518) 761-9797
FAX (518) 761-9798