

Stainless Steel Check Valve

Model 812X



Flomatic Corporation

Sizes 1/2" / 15mm

LEAD FREE
NSF/ANSI 61



Materials

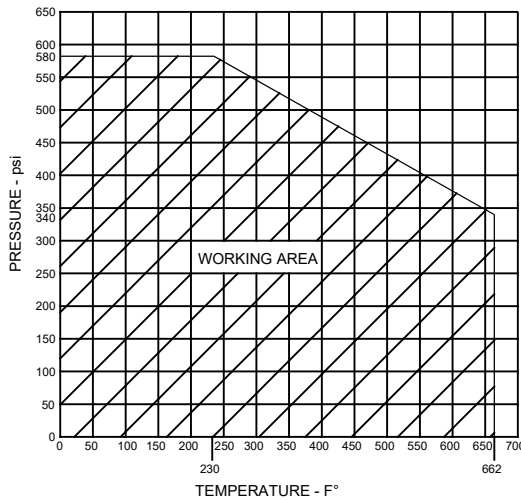
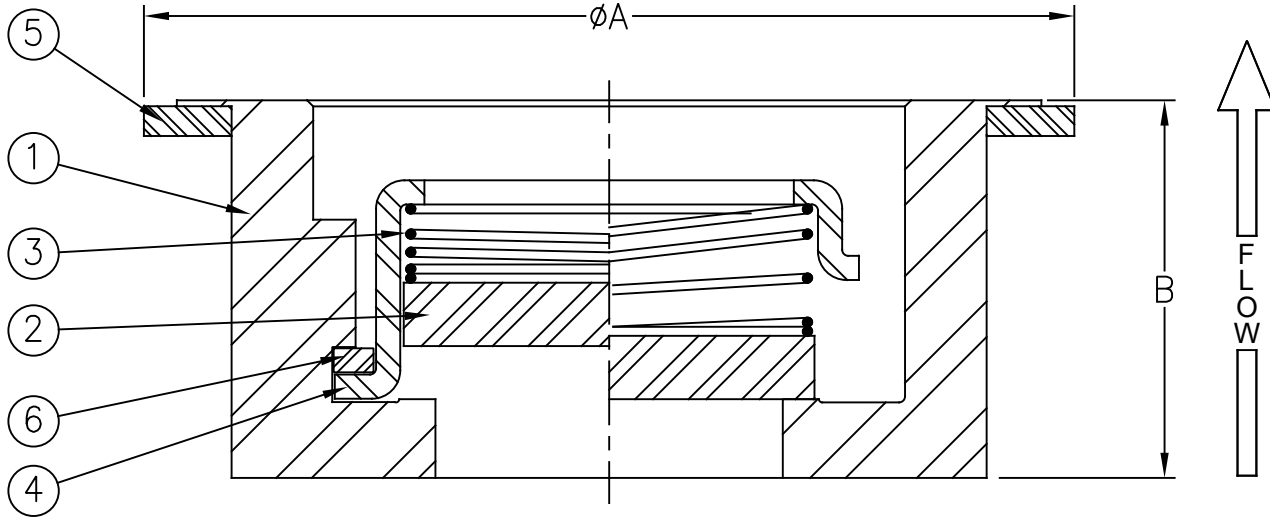

Max Temp 662°F (350°C)
Max Pressure 580psi (40bar)

Item #	Qty	Description	Material	ASTM
1	1	Body	Stainless Steel	316
2	1	Disc*	Stainless Steel	316
3	1	Spring	Stainless Steel	316
4	1	Guide	Stainless Steel	316
5	1	Centering Collar	Stainless Steel	316
6	A/R	Clips	Stainless Steel	316

*Metal to metal seating only

Dimensions

Size		Part #	A		B		Weight	
inch	mm		inch	mm	inch	mm	lbs	kg
1/2	15	2420X	2.09	53	.63	16	.22	.10

Flomatic Corporation can accept no responsibility for possible errors in catalogues, brochures and other printed material. Flomatic Corporation reserves the right to alter its products without notices. This also applies to product already agreed. All trademarks in this material are property of the respective companies. All rights reserved. ©2023 Flomatic Corporation. The drawings & information on this drawing sheet are the sole & exclusive property of Flomatic Corporation. Any reproduction, distribution, display or use of these drawings or information in whole or in part without written authorization of Flomatic Corporation is strictly prohibited. www.flomatic.com



January 25, 2005
Dwg No: S812X-1 Rev: J (3/24)

FLOMATIC CORPORATION
GLENS FALLS, N.Y. 12801
PHONE (518) 761-9797
FAX (518) 761-9798