

Stainless Steel Check Valve

Model 812XT



Sizes 5" thru 8" / 125mm thru 200mm

Materials

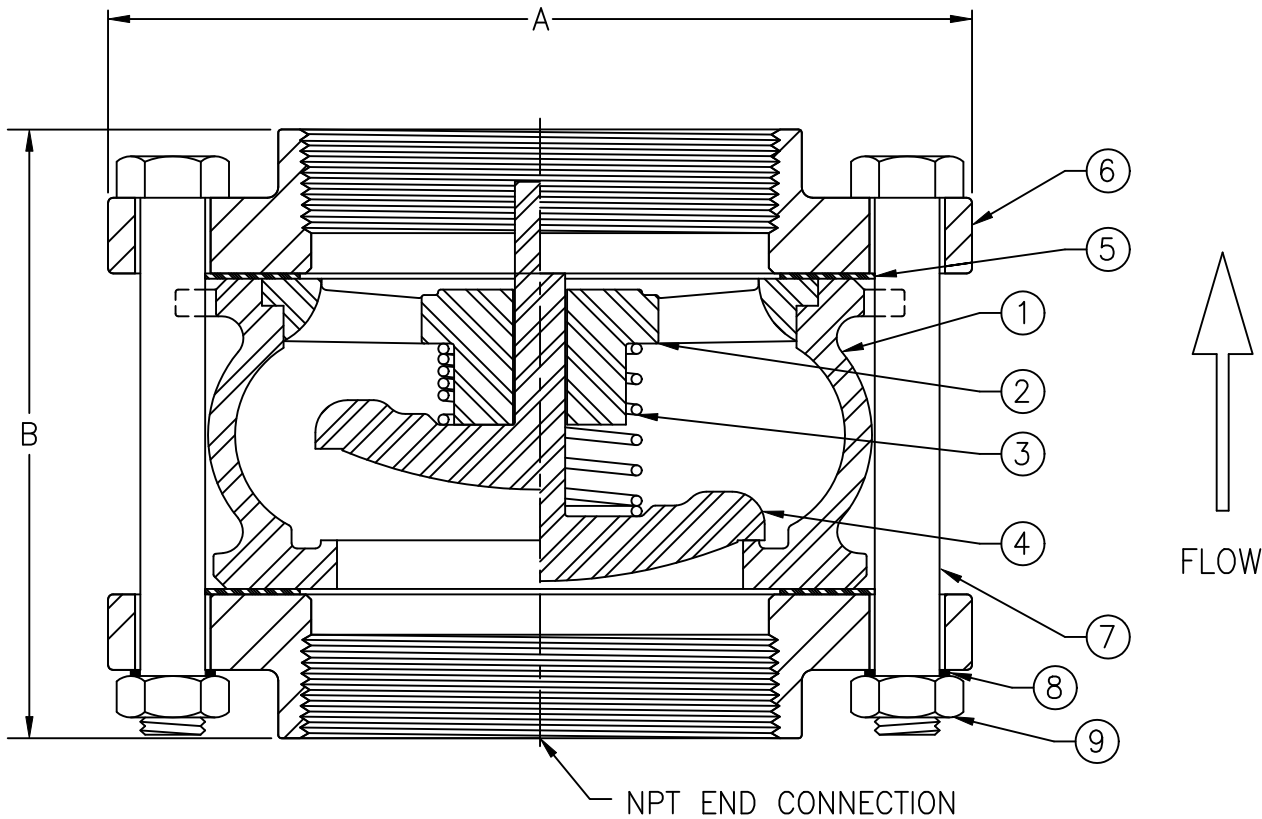

| Item # | Qty | Description | Material | ASTM |
|--------|-----|-----------------|-----------------|-------|
| 1 | 1 | Body | Stainless Steel | 316 |
| 2 | 1 | Spring Retainer | Stainless Steel | 316 |
| 3 | 1 | Spring | Stainless Steel | 316 |
| 4 | 1 | Disc | Stainless Steel | 316 |
| 5 | 2 | Flange Seal | Vellumoid | ----- |
| 6 | 2 | Flange | Stainless Steel | 316 |
| 7 | A/R | Hex Head Bolt | Stainless Steel | 316 |
| 8 | A/R | Hex Washer | Stainless Steel | 316 |
| 9 | A/R | Hex Head Nut | Stainless Steel | 316 |

Dimensions

ALSO AVAILABLE WITH SOCKET WELD END CONNECTIONS - MODEL 812XS

Max Temp 180°F (82°C)
Max Pressure 600psi (41bar)

| Size | | Part # | A | | B | | Weight | |
|------|-----|--------|------|-----|------|-----|--------|------|
| inch | mm | | inch | mm | inch | mm | lbs | kg |
| 5 | 125 | 2429XT | 10 | 254 | 6.75 | 171 | 60 | 27.2 |
| 6 | 150 | 2430XT | 11 | 279 | 7.56 | 192 | 77 | 34.9 |
| 8 | 200 | 2431XT | 13.5 | 343 | 9.50 | 241 | 136 | 61.7 |

Flomatic Corporation can accept no responsibility for possible errors in catalogues, brochures and other printed material. Flomatic Corporation reserves the right to alter its products without notices. This also applies to product already agreed. All trademarks in this material are property of the respective companies. All right reserved. ©2011 Flomatic Corporation. The drawings & information on this drawing sheet are the sole & exclusive property of Flomatic Corporation. Any reproduction, distribution, display or use of these drawings or information in whole or in part without written authorization of Flomatic Corporation is strictly prohibited.



March 10, 1995
Dwg No: S812XT-4 Rev: D (7/13)

FLOMATIC CORPORATION
GLENS FALLS, N.Y. 12801
PHONE (518) 761-9797
FAX (518) 761-9798