

Stainless Steel Check Valve

Model 100MSS



Flomatic Corporation

Sizes 3/4" / 20mm

Materials

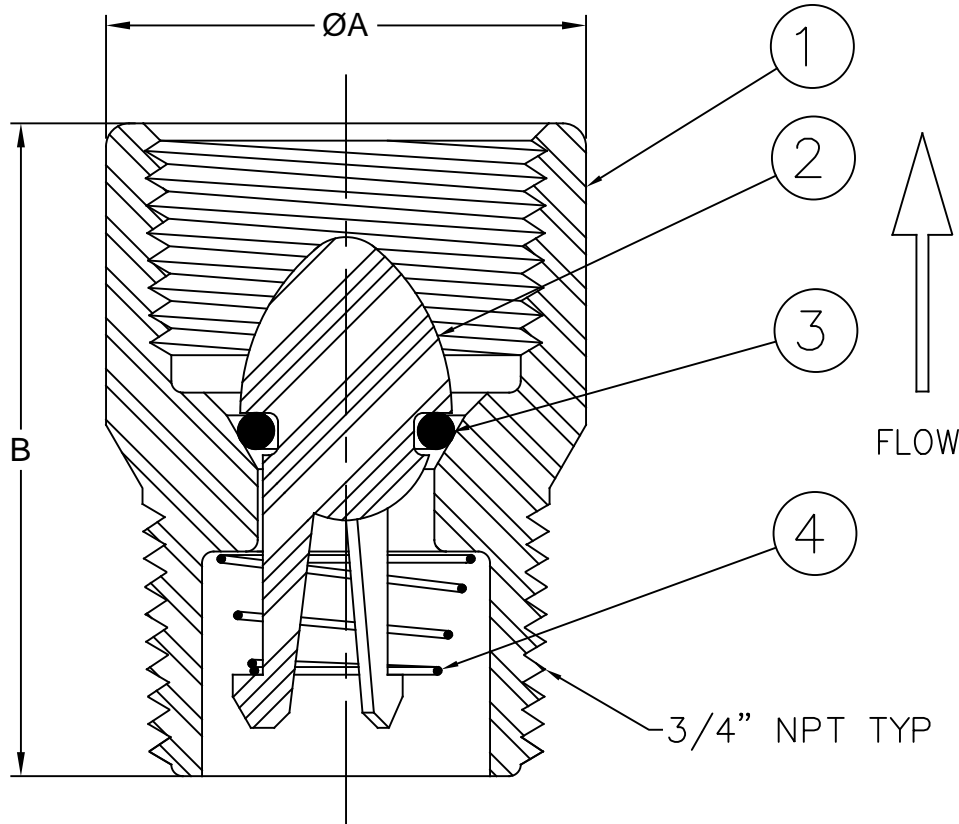
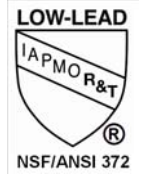

Max Temp 180°F (80°C)
Max Pressure 400psi (28bar)

Item #	Qty	Description	Material	ASTM	Item #	Qty	Description	Material	ASTM
1	1	Body	Stainless Steel	303	3	1	O'Ring	Viton	-----
2	1	Poppet	Celcon	-----	4	1	Spring	Stainless Steel	302

Dimensions (MNPT X FNPT)

Size		Part #	A		B		Weight	
inch	mm		inch	mm	inch	mm	lbs	kg
3/4	20	4218SS	1-1/4	32	1-45/64	43	.5	.23

Flomatic Corporation can accept no responsibility for possible errors in catalogues, brochures and other printed material. Flomatic Corporation reserves the right to alter its products without notices. This also applies to product already agreed. All trademarks in this material are property of the respective companies. All rights reserved. ©2019 Flomatic Corporation. The drawings & information on this drawing sheet are the sole & exclusive property of Flomatic Corporation. Any reproduction, distribution, display or use of these drawings or information in whole or in part without written authorization of Flomatic Corporation is strictly prohibited. www.flomatic.com



October 29, 1993
Dwg No: S4218SS Rev: G (9/19)

FLOMATIC CORPORATION
GLENS FALLS, N.Y. 12801
PHONE (518) 761-9797
FAX (518) 761-9798