

Stainless Steel Check Valve

Model 100MSS



Sizes 1" / 25mm

LEAD FREE
NSF/ANSI 61



Materials

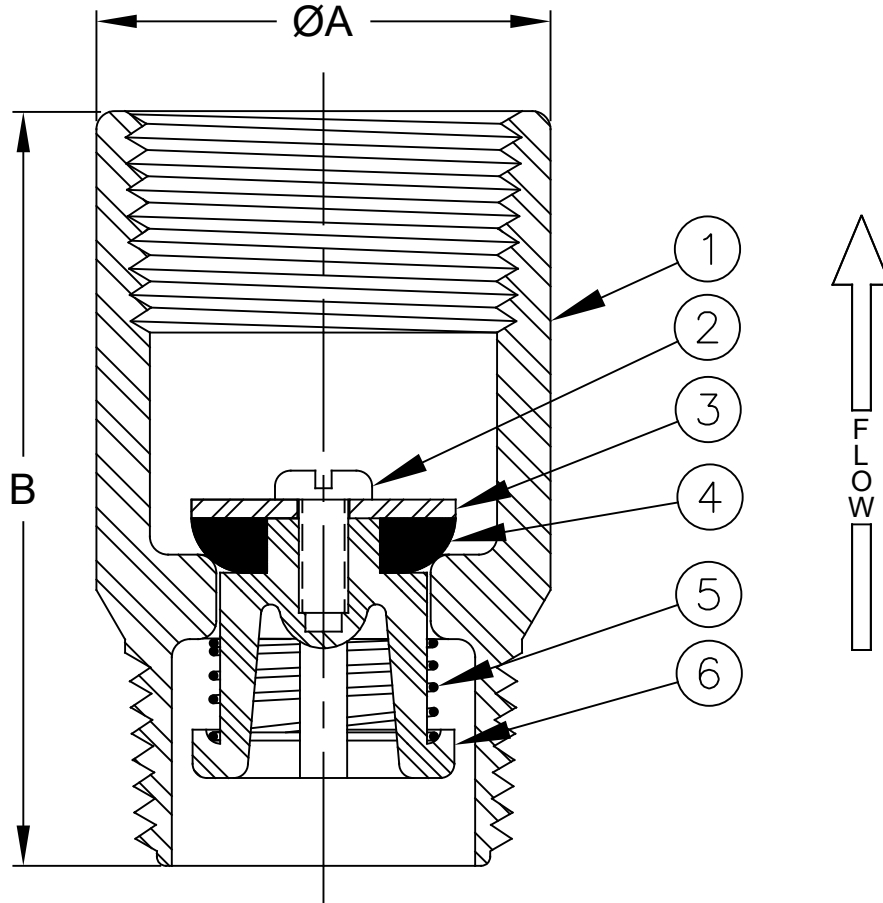

Max Temp 180°F (80°C)
Max Pressure 400psi (28bar)

Item #	Qty	Description	Material	ASTM	Item #	Qty	Description	Material	ASTM
1	1	Body	Stainless Steel	304	4	1	Disc	Buna-n	N-5007
2	1	Screw	Stainless Steel	302	5	1	Spring	Stainless Steel	302
3	1	Washer	Stainless Steel	18-8	6	1	Guide	Celcon®	M90

Dimensions (MNPT X FNPT)

ANSI B1.20.1

Size		Part #	A		B		Weight	
inch	mm		inch	mm	inch	mm	lbs	kg
1	25	4220SS	1-1/2	38	2-1/2	63	1	.45

Flomatic Corporation can accept no responsibility for possible errors in catalogues, brochures and other printed material. Flomatic Corporation reserves the right to alter its products without notices. This also applies to product already agreed. All trademarks in this material are property of the respective companies. All rights reserved. ©2024 Flomatic Corporation. The drawings & information on this drawing sheet are the sole & exclusive property of Flomatic Corporation. Any reproduction, distribution, display or use of these drawings or information in whole or in part without written authorization of Flomatic Corporation is strictly prohibited. www.flomatic.com



March 3, 1994
Dwg No: S4220SS Rev: F (1/24)

FLOMATIC CORPORATION
GLENS FALLS, N.Y. 12801
PHONE (518) 761-9797
FAX (518) 761-9798