

Stainless Steel Check Valve

Model 100MLSS



Flomatic Corporation

Sizes 1-1/4"M x 1"F / 32mm x 25mm



Materials

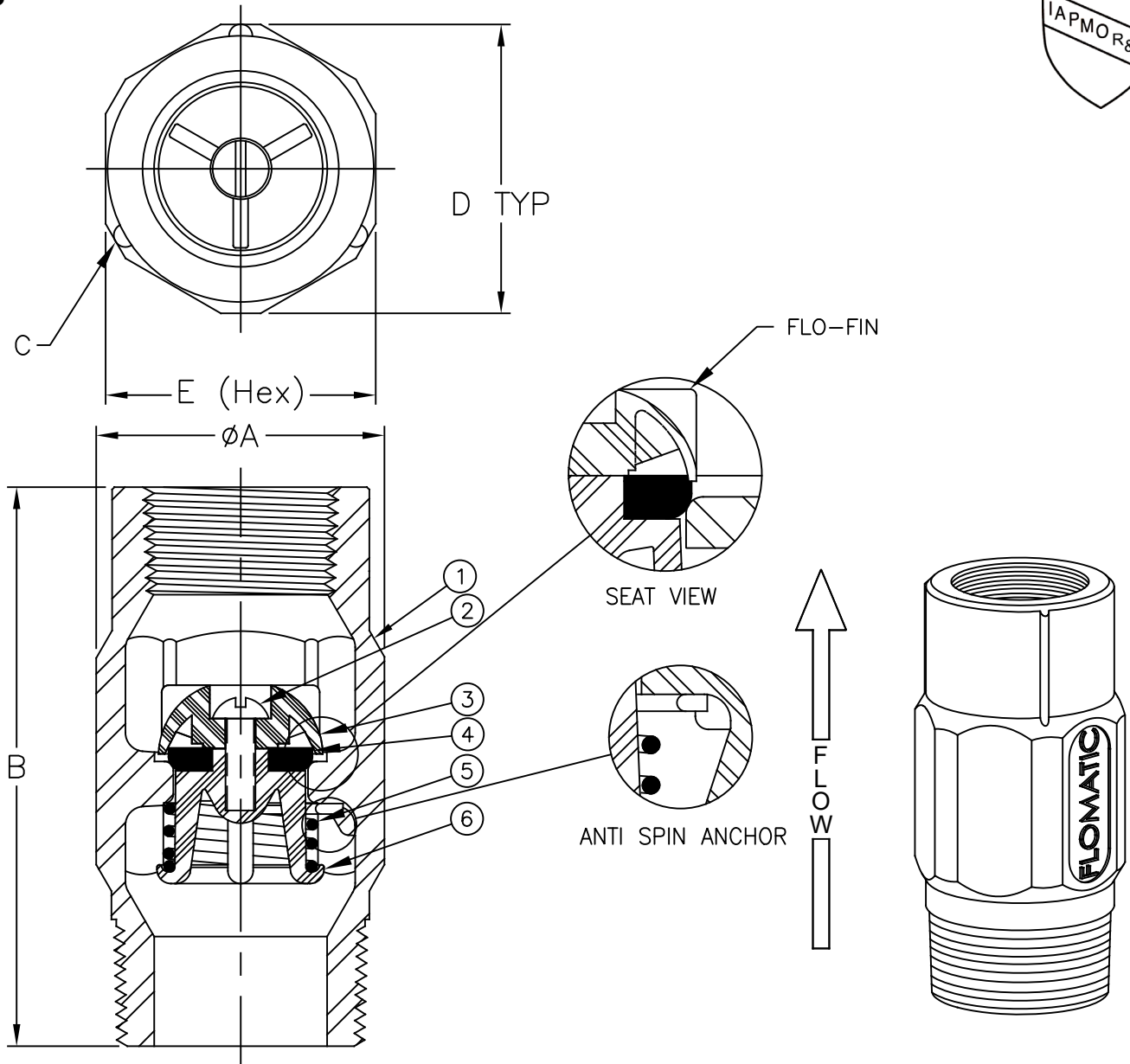

Max Temp 180°F (82°C)
Max Pressure 400psi (28bar)

Item #	Qty	Description	Material	ASTM	Item #	Qty	Description	Material	ASTM
1	1	Body	Stainless Steel	304	4	1	Disc	Buna-n	N-5007
2	1	Screw	Stainless Steel	302	5	1	Spring	Stainless Steel	302
3	1	Dome	Delrin	500P	6	1	Guide	Celcon®	M90

Dimensions (MNPT X FNPT)

Patent # 4,971,09 & 6,581,633

ANSI B1.20.1

Size		Part #	A		B		C		D		E		Weight	
inch	mm		inch	mm	inch	mm	inch	mm	inch	mm	inch	mm	lbs	kg
1-1/4 x 1	32 x 25	4221LSS2	1-29/32	48	3-7/8	98	5/64	2	1-29/32	48	1-51/64	45	1.5	.68

Flomatic Corporation can accept no responsibility for possible errors in catalogues, brochures and other printed material. Flomatic Corporation reserves the right to alter its products without notices. This also applies to product already agreed. All trademarks in this material are property of the respective companies. All rights reserved. ©2024 Flomatic Corporation. The drawings & information on this drawing sheet are the sole & exclusive property of Flomatic Corporation. Any reproduction, distribution, display or use of these drawings or information in whole or in part without written authorization of Flomatic Corporation is strictly prohibited. www.flomatic.com



January 18, 2000
Dwg No: S4221SSL2 Rev: H (1/24)

FLOMATIC CORPORATION
GLENS FALLS, N.Y. 12801
PHONE (518) 761-9797
FAX (518) 761-9798