

Stainless Steel Check Valve

Model 100MSS



Sizes 1-1/4"M x 1-1/4"F / 32mm x 32mm

Materials

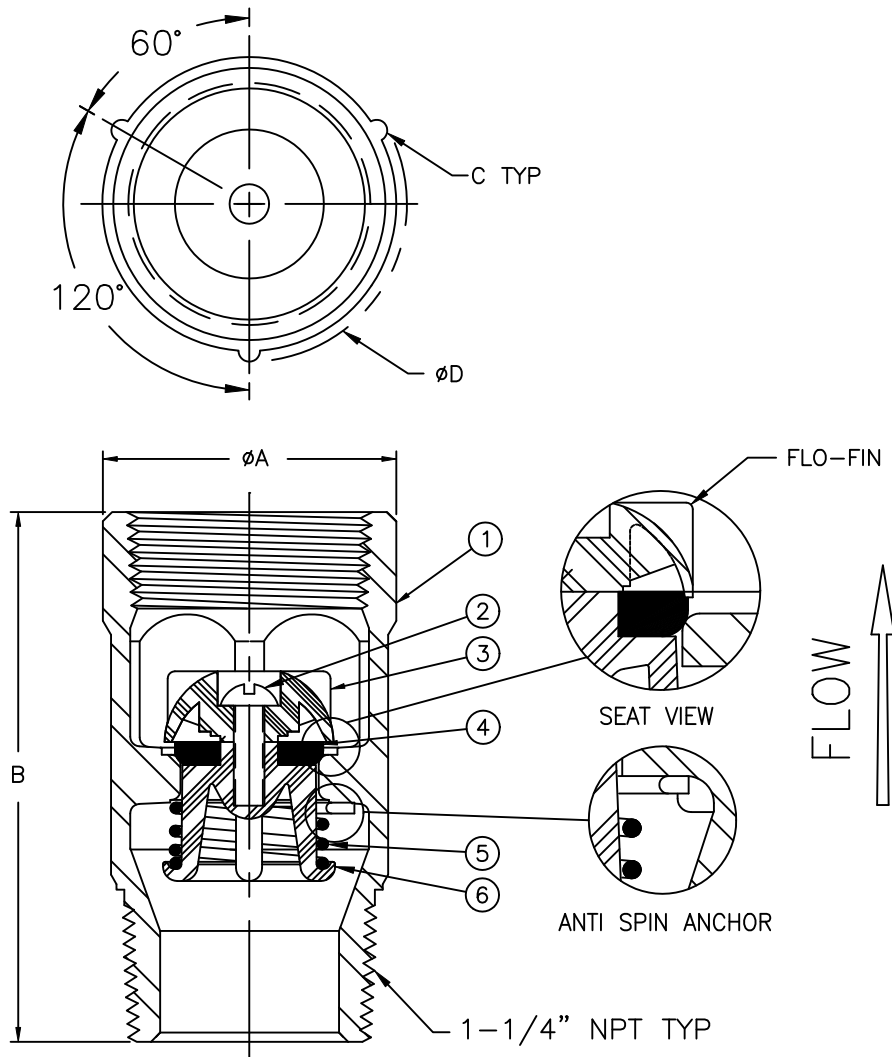

Max Temp 180°F (82°C)
Max Pressure 400psi (28bar)

Item #	Qty	Description	Material	ASTM	Item #	Qty	Description	Material	ASTM
1	1	Body	Stainless Steel	303	4	1	Disc	Buna-n	-----
2	1	Screw	Stainless Steel	18-8	5	1	Spring	Stainless Steel	18-8
3	1	Dome	Delrin	-----	6	1	Guide	Delrin	-----

Dimensions

Patent # 4,971,09 & 6,581,633

Size		Part #	A		B		C		D		Weight	
inch	mm		inch	mm	inch	mm	inch	mm	inch	mm	lbs	kg
1-1/4 x 1-1/4	32 x 32	4242SS2	1-29/32	48	3-29/64	88	5/64	2	2-1/16	52	1.5	.68

Flomatic Corporation can accept no responsibility for possible errors in catalogues, brochures and other printed material. Flomatic Corporation reserves the right to alter its products without notices. This also applies to product already agreed. All trademarks in this material are property of the respective companies. All right reserved. ©2011 Flomatic Corporation. The drawings & information on this drawing sheet are the sole & exclusive property of Flomatic Corporation. Any reproduction, distribution, display or use of these drawings or information in whole or in part without written authorization of Flomatic Corporation is strictly prohibited.



October 31, 1996
Dwg No: S4242SS2 Rev: E (4/13)

FLOMATIC CORPORATION
GLENS FALLS, N.Y. 12801
PHONE (518) 761-9797
FAX (518) 761-9798