

# Stainless Steel Check Valve

Model 100XLSS **FLOMATIC®**

Sizes 1" / 25 mm (Male X Female)

Flomatic Corporation

## Materials

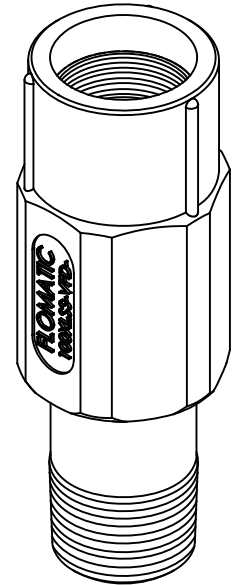
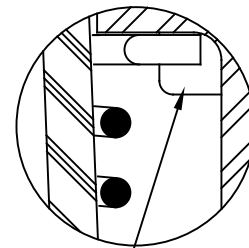
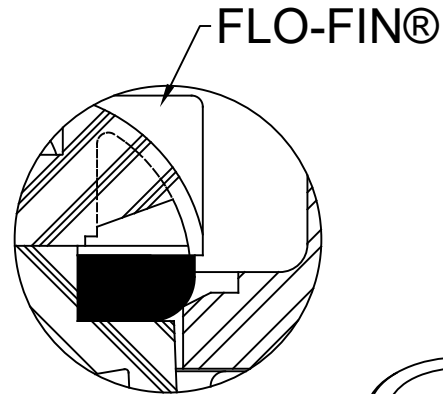
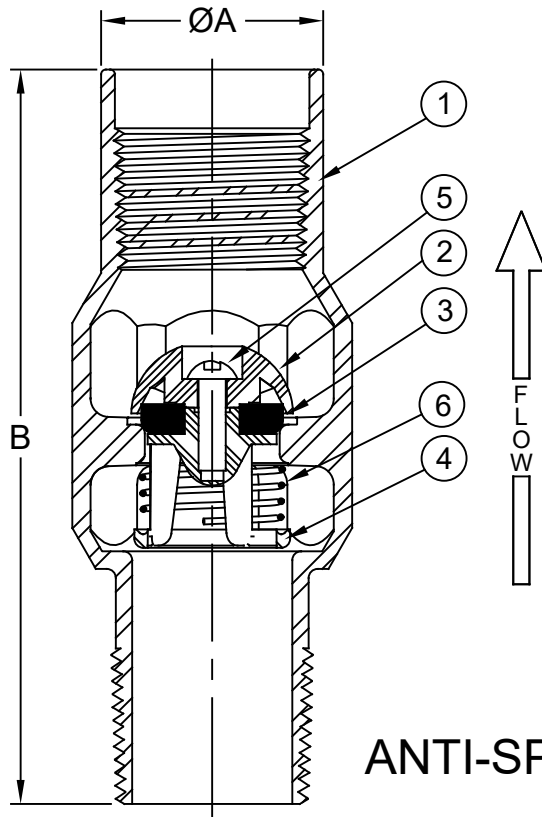
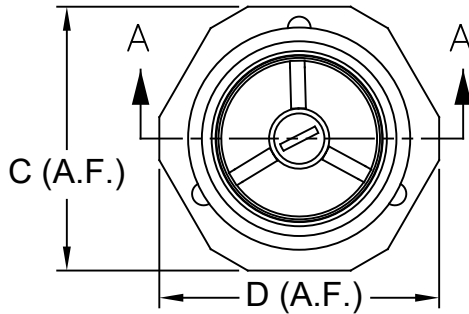

Max Temp 180°F (82°C)  
Max Pressure 400psi (28bar)

Item #	Qty	Description	Material	ASTM	Item #	Qty	Description	Material	ASTM
1	1	Body	Stainless Steel	303	4	1	Guide	Delrin	-----
2	1	Dome	Delrin	-----	5	1	Screw	Stainless Steel	302
3	1	Disc	Buna-n	-----	6	1	Spring	Stainless Steel	302

## Dimensions (MNPT x FNPT)

ANSI B1.20.1

Size		Part #	A		B		C		D		Weight	
inch	mm		inch	mm	inch	mm	inch	mm	inch	mm	lbs	kg
1	25	4201XLSS2	1-33/64	38	5-1/4	133	1-51/64	46	1-29/32	48	2	.9

Patent # 4,971,09 & 6,581,633

Flomatic Corporation can accept no responsibility for possible errors in catalogues, brochures and other printed material. Flomatic Corporation reserves the right to alter its products without notices. This also applies to product already agreed. All trademarks in this material are property of the respective companies. All rights reserved. ©2022 Flomatic Corporation. The drawings & information on this drawing sheet are the sole & exclusive property of Flomatic Corporation. Any reproduction, distribution, display or use of these drawings or information in whole or in part without written authorization of Flomatic Corporation is strictly prohibited. [www.flomatic.com](http://www.flomatic.com)