

# Stainless Steel Check Valve

Model 80S6 **FLOMATIC**<sup>®</sup>

Sizes 8" / 200mm

Flomatic Corporation

## Materials

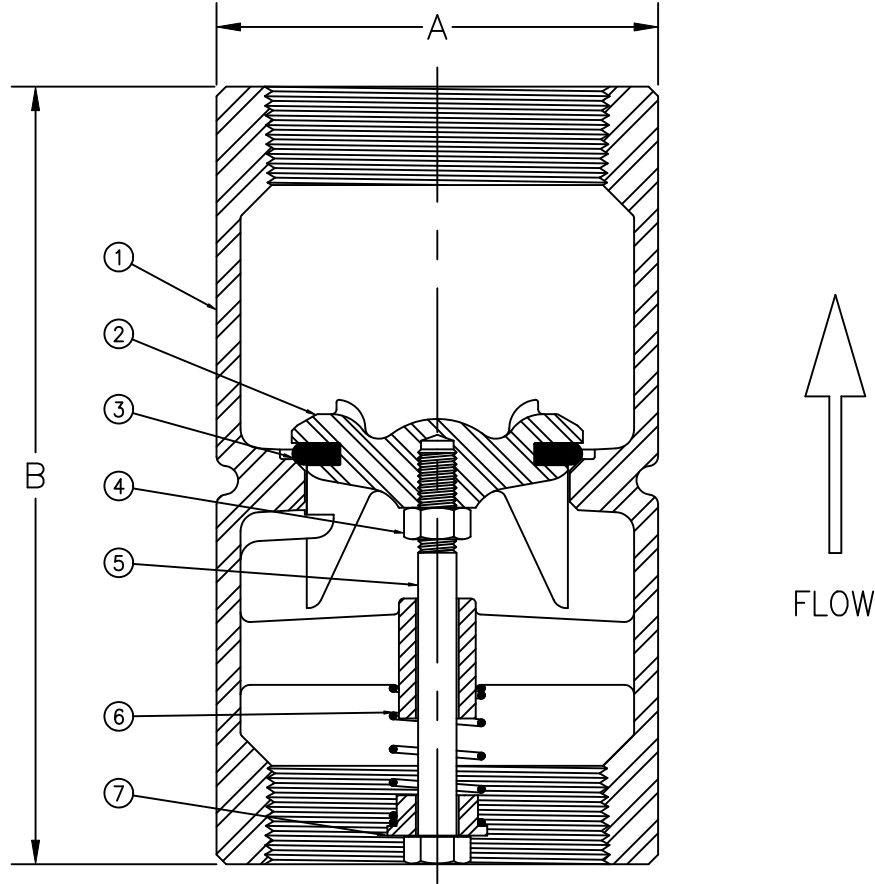

Max Temp 400°F (200°C)  
Max Pressure 400psi (28bar)

Item #	Qty	Description	Material	ASTM	Item #	Qty	Description	Material	ASTM
1	1	Body	Stainless Steel	316	5	1	Spring	Stainless Steel	316
2	1	Poppet	Stainless Steel	316	6	1	Retainer	Stainless Steel	316
3	1	Seat Seal	Viton	-----	7	1	Bolt	Stainless Steel	316
4	1	Nut	Stainless Steel	316					

## Dimensions (FNPT x FNPT)

Double guided poppet suitable for vertical or horizontal installation

Size		Part #	A		B		Weight	
inch	mm		inch	mm	inch	mm	lbs	kg
8	200	4090XSS	9-11/16	246	15-7/8	403	90	41

Flomatic Corporation can accept no responsibility for possible errors in catalogues, brochures and other printed material. Flomatic Corporation reserves the right to alter its products without notices. This also applies to product already agreed. All trademarks in this material are property of the respective companies. All right reserved. ©2016 Flomatic Corporation. The drawings & information on this drawing sheet are the sole & exclusive property of Flomatic Corporation. Any reproduction, distribution, display or use of these drawings or information in whole or in part without written authorization of Flomatic Corporation is strictly prohibited.