

Stainless Steel Check Valve

Model 80S6 **FLOMATIC**[®]

Sizes 10" / 250mm

Flomatic Corporation

Materials

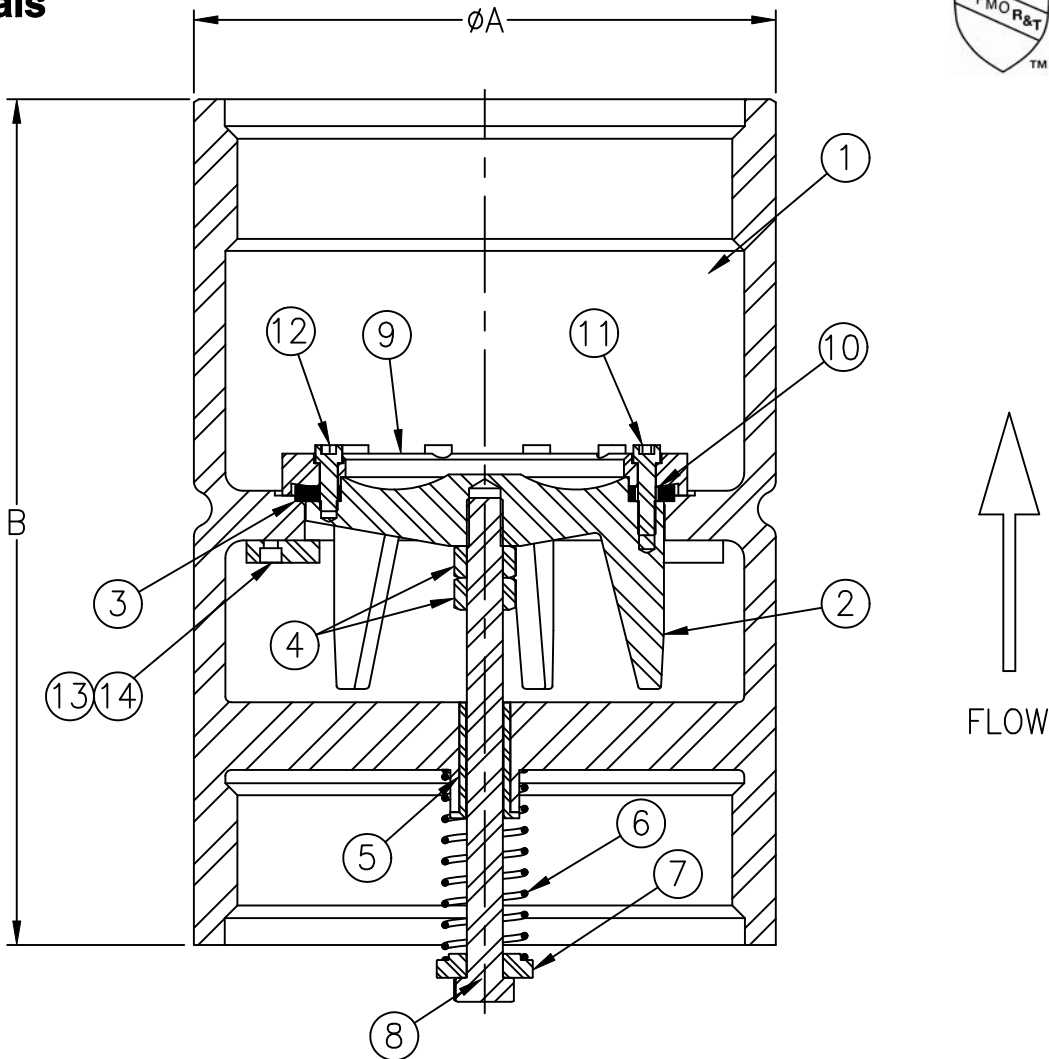

Max Temp 400°F (200°C)
Max Pressure 400psi (28bar)

Item #	Qty	Description	Material	ASTM	Item #	Qty	Description	Material	ASTM
1	1	Body	Stainless Steel	316	8	1	Bolt	Stainless Steel	316
2	1	Guide	Stainless Steel	316	9	1	Poppet Retainer Ring	Stainless Steel	316
3	1	Gasket	Viton	-----	10	5	Spacer	Stainless Steel	316
4	2	Nut	Stainless Steel	316	11	5	SHCS	Stainless Steel	316
5	1	Bushing	Stainless Steel	316	12	5	SHCS	Stainless Steel	316
6	1	Spring	Stainless Steel	316	13	3	Anti-Spin Lug	Stainless Steel	316
7	1	Spring Retainer	Stainless Steel	316	14	6	SHCS	Stainless Steel	316

Dimensions (FNPT X FNPT)

Double guided poppet suitable for vertical or horizontal installation

Size		Part #	A		B		Weight	
inch	mm		inch	mm	inch	mm	lbs	kg
10	250	4091XSS	12-1/8	308	17-5/8	448	170	77

Flomatic Corporation can accept no responsibility for possible errors in catalogues, brochures and other printed material. Flomatic Corporation reserves the right to alter its products without notices. This also applies to product already agreed. All trademarks in this material are property of the respective companies. All right reserved. ©2016 Flomatic Corporation. The drawings & information on this drawing sheet are the sole & exclusive property of Flomatic Corporation. Any reproduction, distribution, display or use of these drawings or information in whole or in part without written authorization of Flomatic Corporation is strictly prohibited.