

Stainless Steel Check Valve

Model 80SSCVFD



Flomatic Corporation

Sizes 1-1/4" / 32 mm
Control Center Tapped

Materials

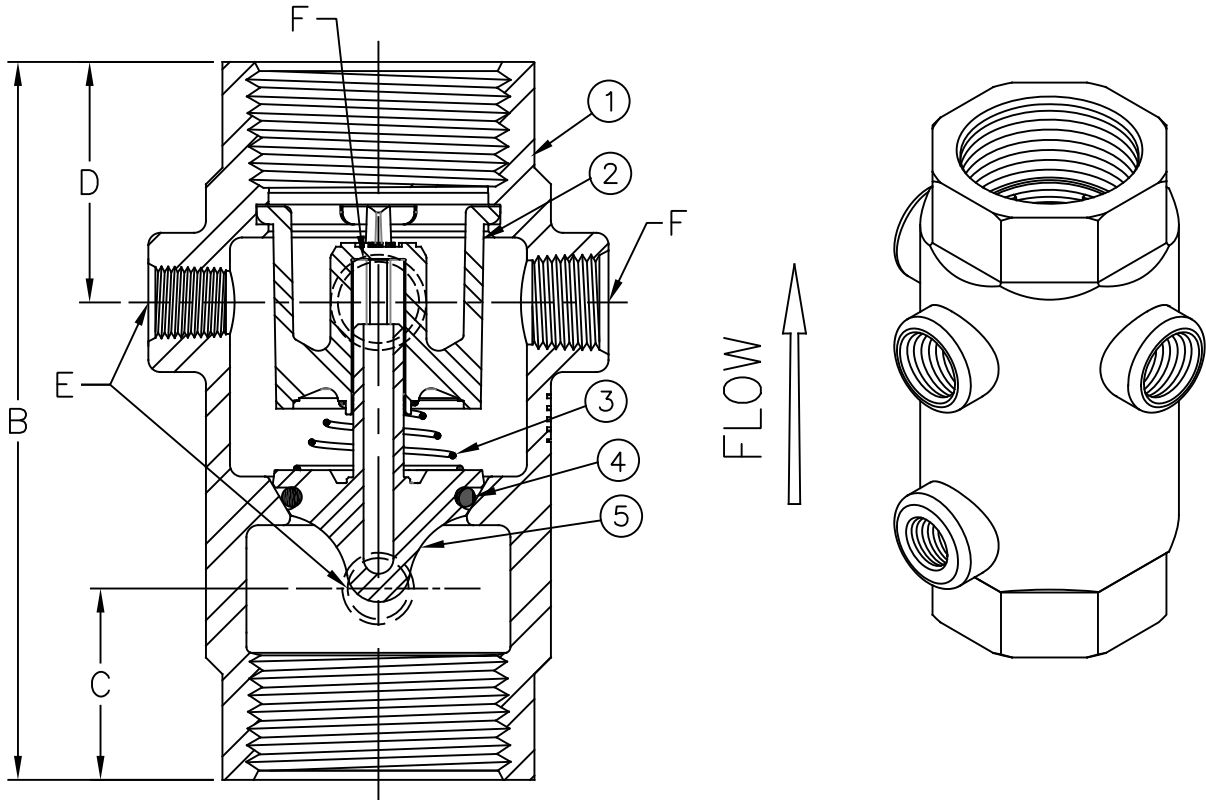
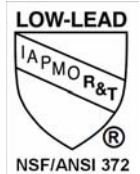
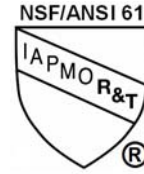

Max Temp 180°F (82°C)
Max Pressure 400 psi (28bar)

Item #	Qty	Description	Material	ASTM	Item #	Qty	Description	Material	ASTM
1	1	Body	Stainless Steel	304	4	1	O-Ring	Buna-n	-----
2	1	Guide	Delrin	100 Black	5	1	Poppet*	Delrin	100 Black
3	1	Spring	Stainless Steel	302	*Optional SS add an S between 2 & VFD				

Dimensions

Patent # 8,978,696

Size		Part #	A		B		C		D		E (NPT)	F (NPT)	Weight	
inch	mm		inch	mm	inch	mm	inch	mm	inch	mm	inch	inch	lbs	kg
1-1/4	32	4062SS2VFD	2-3/8	60	4-19/32	117	1-3/16	29	1-23/32	44	1/8	1/4	2	.91

Flomatic Corporation can accept no responsibility for possible errors in catalogues, brochures and other printed material. Flomatic Corporation reserves the right to alter its products without notices. This also applies to product already agreed. All trademarks in this material are property of the respective companies. All right reserved. ©2018 Flomatic Corporation. The drawings & information on this drawing sheet are the sole & exclusive property of Flomatic Corporation. Any reproduction, distribution, display or use of these drawings or information in whole or in part without written authorization of Flomatic Corporation is strictly prohibited.



April 25, 2017
Dwg No: S4062SS2VFD Rev: A (1/18)

FLOMATIC CORPORATION
GLENS FALLS, N.Y. 12801
PHONE (518) 761-9797
FAX (518) 761-9798