

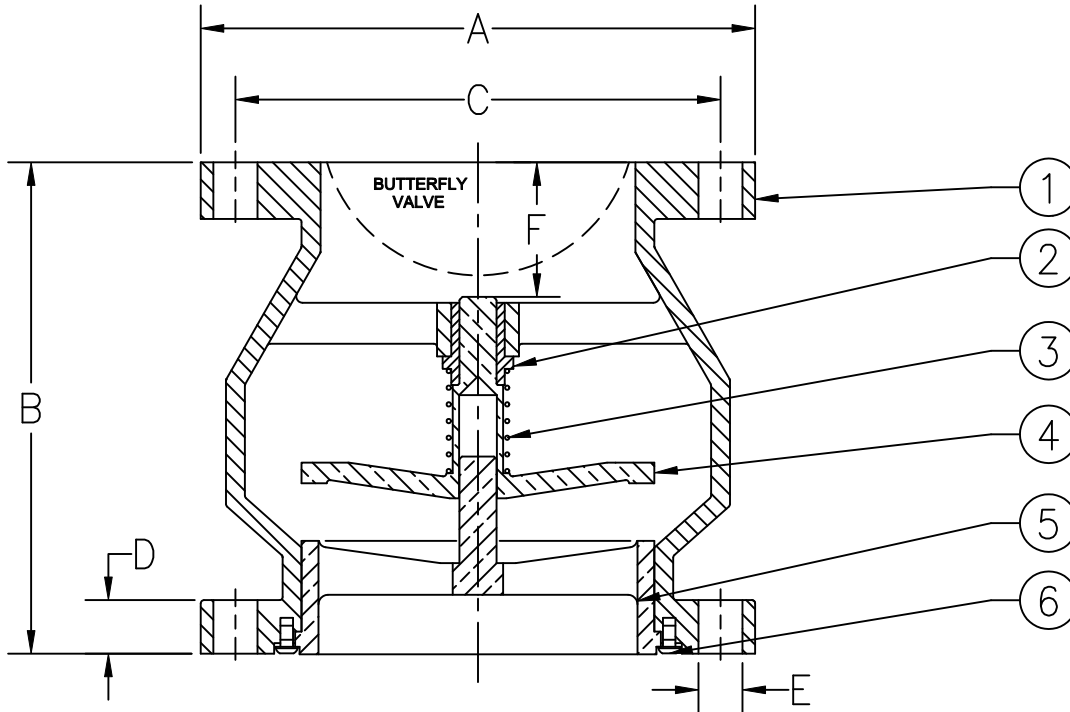

Materials



Item #	Qty	Description	Material	ASTM
1	1	Body (Epoxy Coated)	Cast Iron	A126 CLASS B
2	1	Bushing	Bronze	C95400
3	1	Spring	Stainless Steel	316
4	1	Poppet	Bronze	C87600
5	1	*Seat Ring	Bronze	C87600
6	3	Button Head Socket Screws	Stainless Steel	316

***OPTIONAL RESILIENT SEAT AVAILABLE, ADD "R" TO THE PART NUMBER**
 Max Temp 0-150°F (-17-66°C) Max Pressure 400psi (28bar)
 Max Temp 151-200°F (66-93°C) Max Pressure 370psi (26bar)

Dimensions

Size		Part #	ØA		B		ØC		D		ØE		F		Weight		Bolt Size	# of Bolts
Inch	mm		Inch	mm	Inch	mm	Inch	mm	Inch	mm	Inch	mm	Inch	mm	lbs	kg		
2-1/2	65	2240BT2	7-1/2	191	5-1/2	140	5-7/8	149	1	25	7/8	22	1-7/16	37	19	9	3/4	8
3	80	2241BT2	8-1/4	210	6	152	6-5/8	168	1-1/8	28	7/8	22	1-3/8	35	25	11	3/4	8
4	100	2242BT2	10	254	7-1/4	184	7-7/8	200	1-1/4	32	7/8	22	1-3/4	44	44	20	3/4	8
5	125	2243BT2	11	279	8-1/2	216	9-1/4	235	1-3/8	35	7/8	22	2	51	54	24	3/4	8
6	150	2244BT2	12-1/2	318	9-3/4	248	10-5/8	270	1-7/16	37	7/8	22	2-1/2	64	80	36	3/4	12

Flomatic Corporation can accept no responsibility for possible errors in catalogues, brochures and other printed material. Flomatic Corporation reserves the right to alter its products without notices. This also applies to product already agreed. All trademarks in this material are property of the respective companies. All right reserved. ©2011 Flomatic Corporation. The drawings & information on this drawing sheet are the sole & exclusive property of Flomatic Corporation. Any reproduction, distribution, display or use of these drawings or information in whole or in part without written authorization of Flomatic Corporation is strictly prohibited.