

Swing Check

Angle

Model 78A



Sizes 3" Thru 8" / 75 mm & 200 mm



Materials

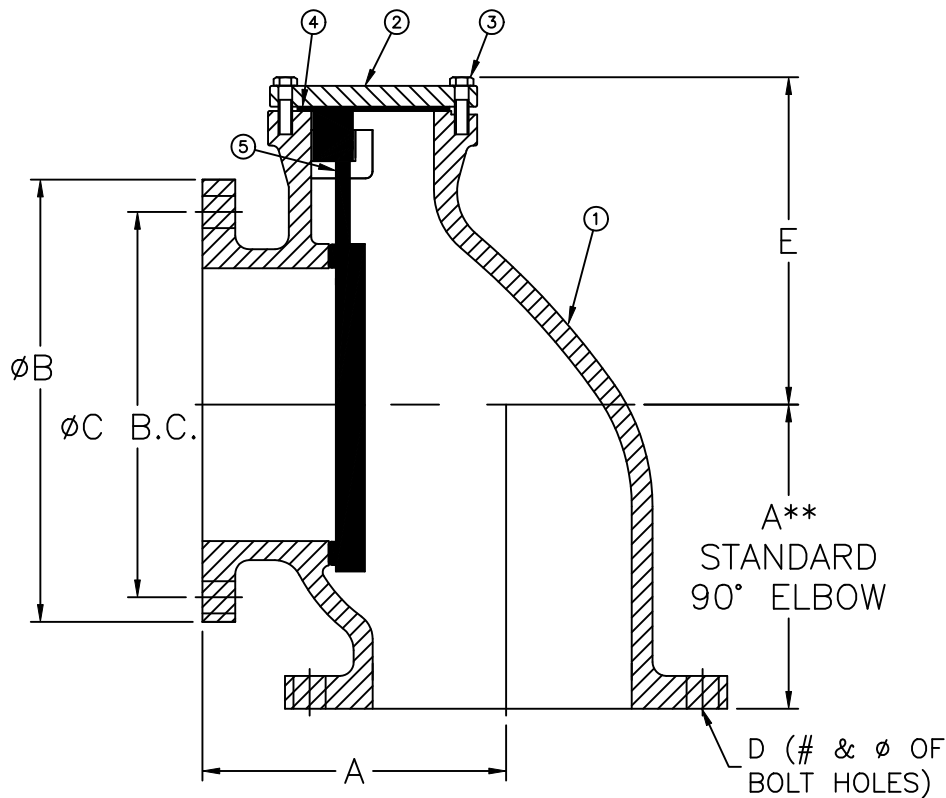

Max Temp 140°F (60°C)
Max Inlet Pressure 175psi (12bar)

Item #	Qty	Description	Material	ASTM
1	1	Body (Epoxy Coated)	Cast Iron	A126, Class B
2	1	Cover (Epoxy Coating)	Cast Iron	A126, Class B
3	A/R	Cover Bolts	Stainless Steel	18-8
4	1	Cover Gasket	Buna-n	-----
5	1	Flapper	Rubber	-----

**ASTM/ANSI B16.1 Class 125 flanged fittings (Table 6)

Dimensions

Size		Part #	A		B		C		D		E (REF)		Weight	
inch	mm		inch	mm	inch	mm	inch	mm	inch	mm	inch	mm	lbs	kg
3	75	2182A	5-1/2	140	7-1/2	191	6	152	(4) 3/4	19	5	127	33	15
4	100	2183A	6-1/2	165	9	229	7-1/2	191	(8) 3/4	19	5-1/4	132	46	21
6	150	2185A	8	203	11	280	9-1/2	241	(8) 7/8	24	7-13/32	188	90	41
8*	200	2186A	9	229	13-1/2	343	11-3/4	299	(8) 7/8	24	8	203	172	79

*Consult factory for availability

Fomatic Corporation can accept no responsibility for possible errors in catalogues, brochures and other printed material. Fomatic Corporation reserves the right to alter its products without notices. This also applies to product already agreed. All trademarks in this material are property of the respective companies. All right reserved. ©2011 Fomatic Corporation. The drawings & information on this drawing sheet are the sole & exclusive property of Fomatic Corporation. Any reproduction, distribution, display or use of these drawings or information in whole or in part without written authorization of Fomatic Corporation is strictly prohibited.



May 29, 2009
Dwg No: S2180-86A Rev: E (3/13)

FLOMATIC CORPORATION
GLENS FALLS, N.Y. 12801
PHONE (518) 761-9797
FAX (518) 761-9798