

Swing Check

Angle

Model 78A



Sizes 10" Thru 14" / 250 mm thru 350 mm



Materials

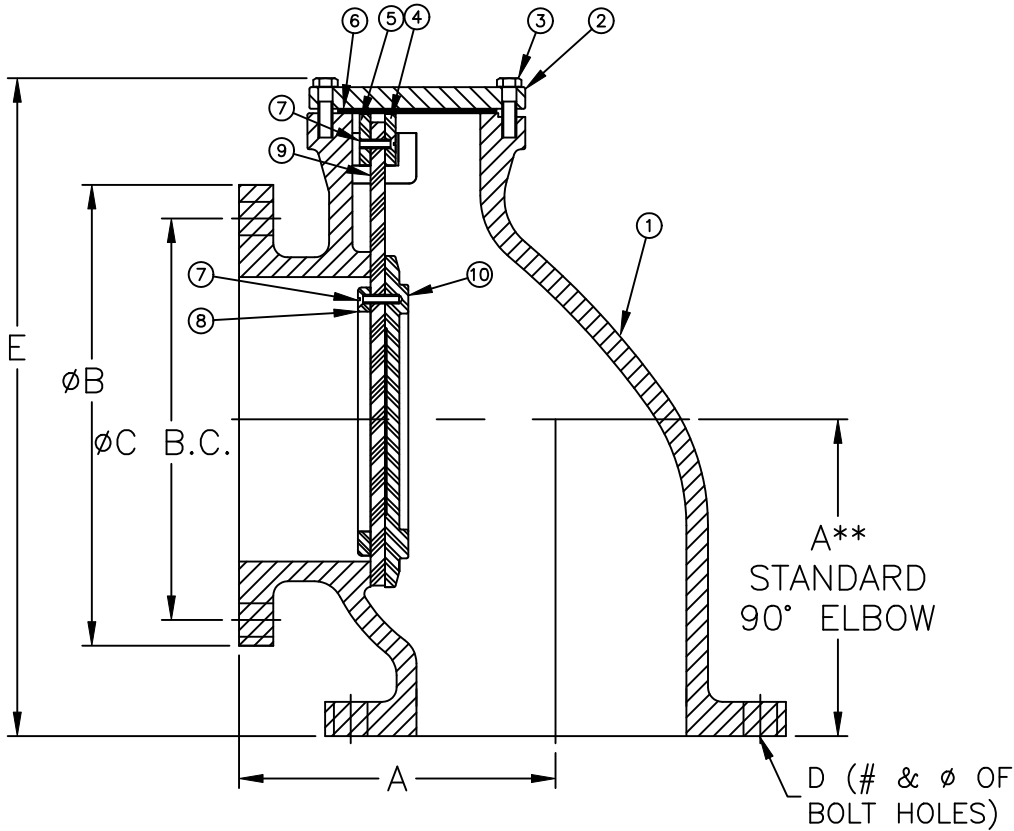

Max Temp 140°F (60°C)
 Max Inlet Pressure 175psi (12bar)
 14" ONLY Max Inlet Pressure 150psi (10bar)

| Item # | Qty | Description | Material | ASTM | Item # | Qty | Description | Material | ASTM |
|--------|-----|---------------------------------|-----------------|---------------|--------|-----|-------------------------------|-----------------|---------------|
| 1 | 1 | Body (Epoxy Coated) | Cast Iron | A126, Class B | 6 | 1 | Cover Gasket | Buna-n | --- |
| 2 | 1 | Cover (Epoxy Coating) | Cast Iron | A126, Class B | 7 | A/R | FHCS | Stainless Steel | 18-8 |
| 3 | A/R | Cover Bolts | Stainless Steel | 18-8 | 8 | 1 | Flapper Ring (Epoxy Coating) | Cast Iron | A126, Class B |
| 4 | 1 | Flapper Support (Epoxy Coating) | Steel | --- | 9 | 1 | Flapper | Rubber | --- |
| 5 | 1 | Flapper Support (Epoxy Coating) | Steel | --- | 10 | 1 | Flapper Plate (Epoxy Coating) | Cast Iron | A126, Class B |

**ASTM/ANSI B16.1 Class 125 flanged fittings (Table 6)

Dimensions

| Size | | Part # | A | | B | | C | | D | | E (REF) | | Weight | |
|------|-----|--------|------|-----|------|-----|--------|-----|------------|----|---------|-----|--------|-----|
| Inch | mm | | Inch | mm | Inch | mm | Inch | mm | Inch | mm | Inch | mm | lbs | kg |
| 10 | 250 | 2187A | 11 | 280 | 16 | 406 | 14-1/4 | 362 | (12) 1 | 25 | 23-7/32 | 590 | 335 | 152 |
| 12 | 300 | 2188A | 12 | 279 | 19 | 483 | 17 | 432 | (12) 1 | 25 | 25-1/2 | 648 | 432 | 196 |
| 14* | 350 | 2189A | 14 | 356 | 21 | 533 | 18-3/4 | 476 | (12) 1-1/8 | 29 | 29-7/16 | 747 | 690 | 313 |

*Consult factory for availability

Flomatic Corporation can accept no responsibility for possible errors in catalogues, brochures and other printed material. Flomatic Corporation reserves the right to alter its products without notices. This also applies to product already agreed. All trademarks in this material are property of the respective companies. All right reserved. ©2011 Flomatic Corporation. The drawings & information on this drawing sheet are the sole & exclusive property of Flomatic Corporation. Any reproduction, distribution, display or use of these drawings or information in whole or in part without written authorization of Flomatic Corporation is strictly prohibited.



June 8, 2009
 Dwg No: S2187A Rev: F (3/13)

FLOMATIC CORPORATION
 GLENS FALLS, N.Y. 12801
 PHONE (518) 761-9797
 FAX (518) 761-9798