

Swing Check Valve

Sizes 4" & 6" / 100 mm & 150 mm

Model 92LS **FLOMATIC**[®]

Flomatic Corporation



Materials (Lever & Spring)

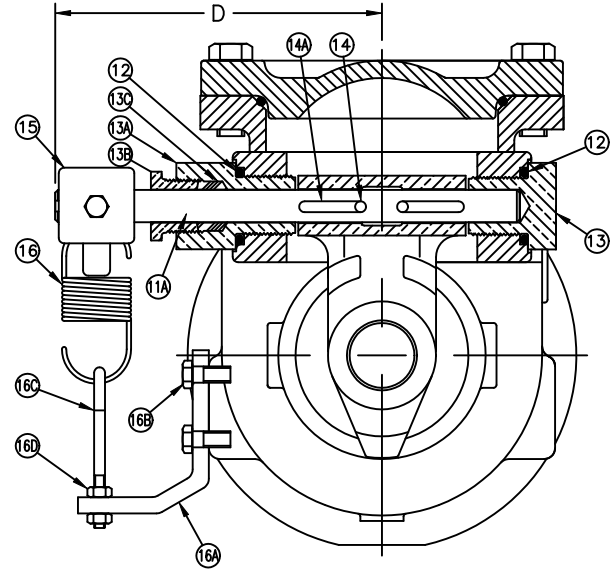
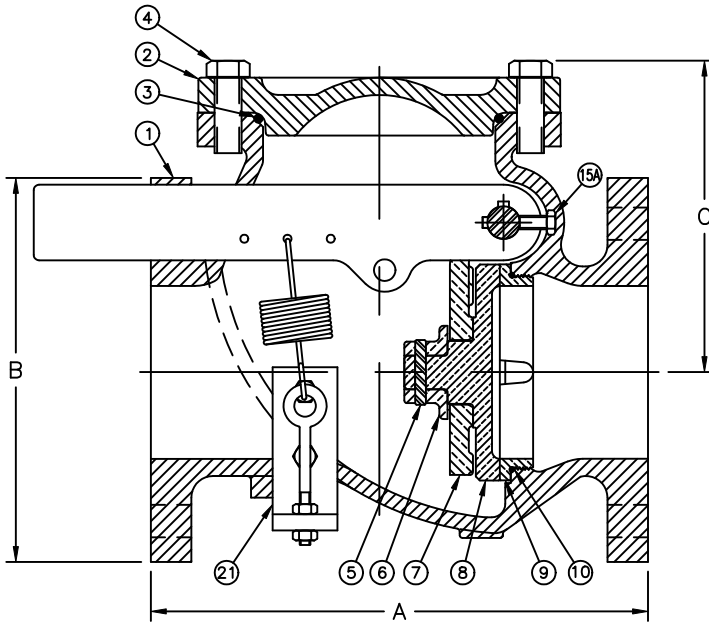

Max Temp 180°F (82°C)
Max Pressure 200psi (14bar)

Item #	Qty	Description	Material	ASTM	Item #	Qty	Description	Material	ASTM
1	1	Body*	Cast Iron	A126	13A	1	Open End Support Shaft Bearing	Bronze	B140
2	1	Cover*	Cast Iron	A126	13B	1	Shaft Packing Nut	Bronze	B140
3	1	Cover O'Ring	Buna-n	-----	13C	4	Teflon Packing	Teflon	-----
4	4	Cover Bolt	Stainless Steel	18-8	14	1	Screw	Stainless Steel	18-8
5	1	Flapper End Cap Pin	Stainless Steel	18-8	14A	3	Key Stock	Stainless Steel	18-8
6	1	Flapper End Cap	Bronze	C89833	15	1	Lever Arm*	Ductile Iron	65-45-12
7	1	Hinge Lever Arm	Bronze	C89833	15A	1	Bolt	Stainless Steel	18-8
8	1	Flapper Plate	Bronze	C89833	16	1	Spring	Stainless Steel	316
9	1	Seat Ring	Bronze	C89833	16A	1	Spring Mounting Bracket*	CRS	-----
10	1	Seat Ring O'Ring	Buna-n	-----	16B	2	Bolt	Zinc Plated	-----
11A	1	Flapper Support Shaft	Stainless Steel	17-4	16C	1	Eyebolt	Zinc Plated	-----
12	2	Bearing O'Ring	Buna-n	-----	16D	2	Nut	Zinc Plated	-----
13	1	Shaft Support Bearing	Bronze	B140	*Epoxy Coated Optional resilient seat (Nitrile) available, add "R" to the end of the part number				

Dimensions

Size		Part #	A		B		C		D		Weight	
inch	mm		inch	mm	inch	mm	inch	mm	inch	mm	lbs	kg
4	100	3707LS	11-1/2	292	8-57/64	226	7-7/32	183	7-9/16	192	119	54
6	150	3709LS	14	356	10-3/4	273	8-17/32	217	8-17/32	217	205	93

MANUFACTURED IN COMPLIANCE WITH AWWA C508 STANDARD

Flomatic Corporation can accept no responsibility for possible errors in catalogues, brochures and other printed material. Flomatic Corporation reserves the right to alter its products without notices. This also applies to product already agreed. All trademarks in this material are property of the respective companies. All right reserved. ©2011 Flomatic Corporation. The drawings & information on this drawing sheet are the sole & exclusive property of Flomatic Corporation. Any reproduction, distribution, display or use of these drawings or information in whole or in part without written authorization of Flomatic Corporation is strictly prohibited.