

# Swing Check Valve

Sizes 8" / 200 mm

Model 92LW **FLOMATIC**

Flomatic Corporation

## Materials (Lever & Weight) (Short Body)

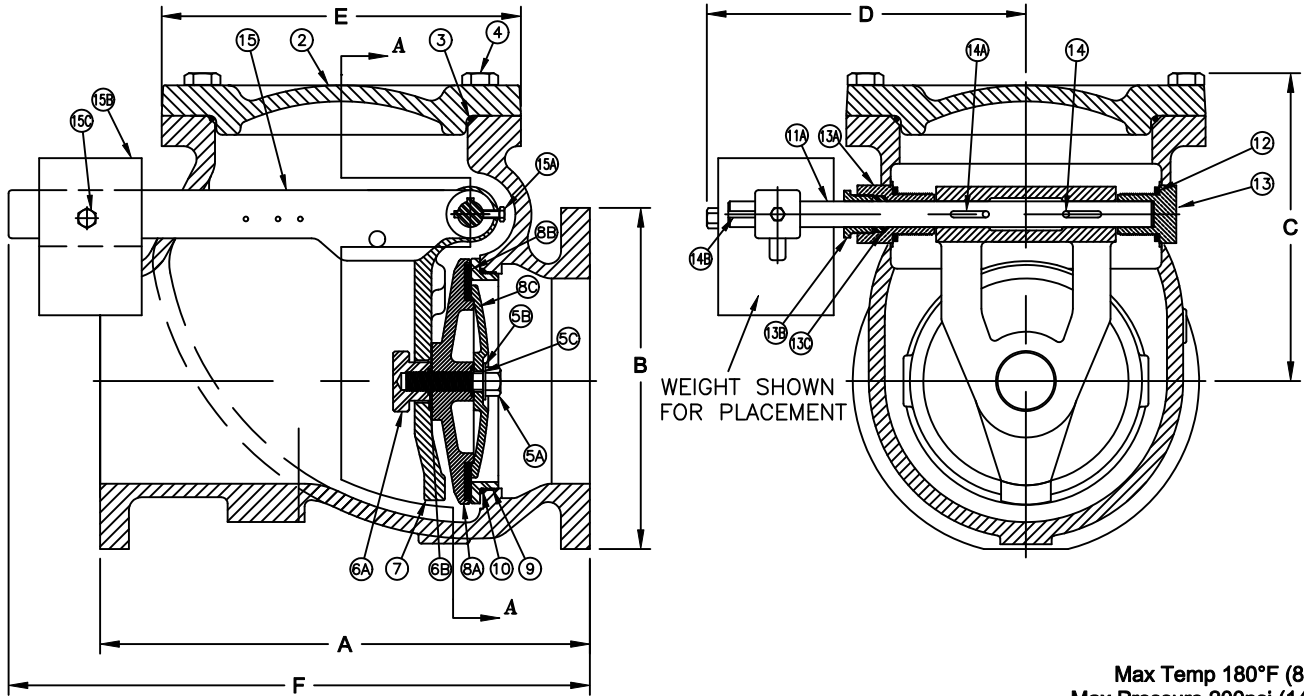

Max Temp 180°F (82°C)  
Max Pressure 200psi (14bar)

Item #	Qty	Description	Material	ASTM	Item #	Qty	Description	Material	ASTM
1	1	Body*	Cast Iron	A126	10	1	Seat Ring O'Ring	Buna-n	—
2	1	Cover*	Cast Iron	A126	11A	1	Flapper Support Shaft	Stainless Steel	17-4
3	1	Cover O'Ring	Buna-n	—	12	2	Bearing O'Ring	Buna-n	—
4	6	Cover Bolt	Stainless Steel	18-8	13	1	Shaft Support Bearing	Bronze	B140
5A	1	Flapper Bolt	Stainless Steel	18-8	13A	1	Open End Support Shaft Bearing	Bronze	B140
5B	1	Flapper Bolt Washer	Stainless Steel	18-8	13B	1	Shaft Packing Nut	Bronze	B140
5C	1	Flapper Bolt O'Ring	Buna-n	—	13C	4	Teflon Packing	Teflon	—
6A	1	Flapper Nut	Stainless Steel	304	14	1	Screw	Stainless Steel	18-8
6B	1	Flapper O'Ring	Buna-n	—	14A	2	Key Stock	Stainless Steel	18-8
7	1	Hinge Lever Arm*	Ductile Iron	65-45-12	14B	1	Key Stock	Stainless Steel	18-8
8A	1	Disc Holder*	Ductile Iron	65-45-12	15	1	Lever Arm*	Ductile Iron	65-45-12
8B	1	Disc	EPDM	—	15A	1	Bolt	Stainless Steel	18-8
8C	1	Disc Retainer*	Ductile Iron	65-45-12	15B	1	Weight*	Cast Iron	A126
9	1	Seat Ring	Bronze	C89833	15C	1	Bolt	Plated	—

\*Epoxy Coated

## Dimensions

Size		Part #	A		B		C		D		E (Ø)		F		Weight	
Inch	mm		Inch	mm	Inch	mm	Inch	mm	Inch	mm	Inch	mm	Inch	mm	lbs	kg
8	200	3710-18LW	18	457	13-29/64	343	12	305	12-7/16	316	14	356	22-21/32	575	340	154

MANUFACTURED IN COMPLIANCE WITH AWWA C508 STANDARD

Flomatic Corporation can accept no responsibility for possible errors in catalogues, brochures and other printed material. Flomatic Corporation reserves the right to alter its products without notices. This also applies to product already agreed. All trademarks in this material are property of the respective companies. All right reserved. ©2011 Flomatic Corporation. The drawings & information on this drawing sheet are the sole & exclusive property of Flomatic Corporation. Any reproduction, distribution, display or use of these drawings or information in whole or in part without written authorization of Flomatic Corporation is strictly prohibited.