

# Swing Check Valve

Sizes 3" & 4" / 75 mm & 100 mm  
 AIS COMPLIANT

Model 745 **FLOMATIC®**  
 Flomatic Corporation



## Materials

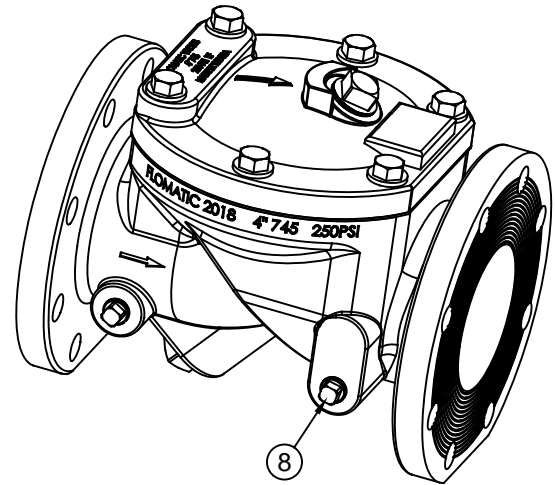
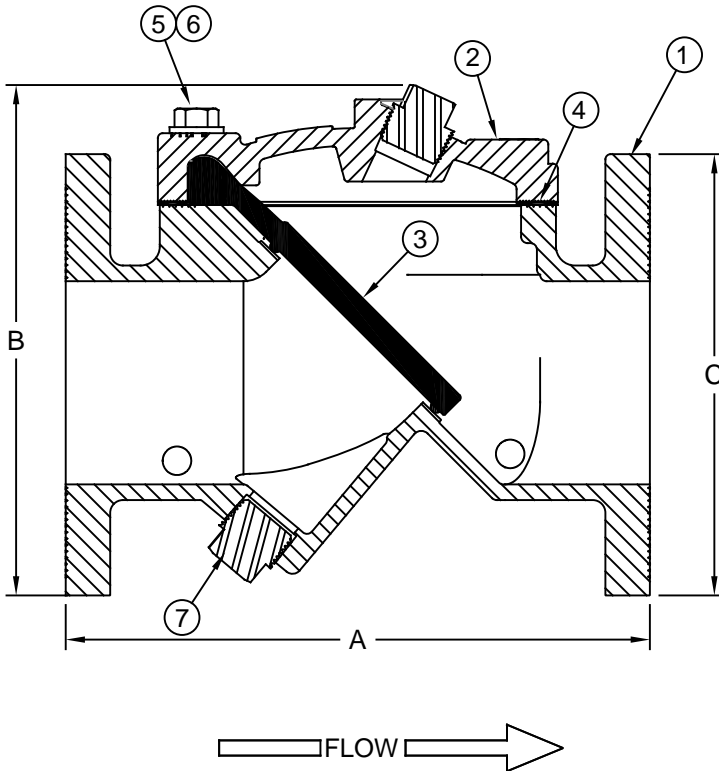

Max Temp 140°F (60°C)  
 Max Pressure 250psi (18bar)

Item #	Qty	Description	Material	ASTM
1	1	Body (Epoxy Coated)	Ductile Iron	65-45-12
2	1	Cover (Epoxy Coated)	Ductile Iron	65-45-12
3	1	Disc*	EPDM (w/ DI disc)	EP5360
4	1	Gasket	EPDM	-----
5	A/R	Cover Bolt	Stainless Steel	304
6	A/R	Washer	Stainless Steel	304
7	2	Pipe Plug	Stainless Steel	304
8	4	Pipe Plug	Stainless Steel	304

## Dimensions (150# ANSI B16.1 Flanges)

Size		Part #	A		B		C		Weight	
inch	mm		inch	mm	inch	mm	inch	mm	lbs	kg
3	80	3382	9-1/2	241	9-3/16	233	7-3/8	187	40	18
4	100	3383	11-1/2	292	10-3/16	259	8-11/16	221	60	27

Flomatic Corporation can accept no responsibility for possible errors in catalogues, brochures and other printed material. Flomatic Corporation reserves the right to alter its products without notices. This also applies to product already agreed. All trademarks in this material are property of the respective companies. All right reserved. ©2019 Flomatic Corporation. The drawings & information on this drawing sheet are the sole & exclusive property of Flomatic Corporation. Any reproduction, distribution, display or use of these drawings or information in whole or in part without written authorization of Flomatic Corporation is strictly prohibited. [www.flomatic.com](http://www.flomatic.com)