

Swing Check Valves

Size 4" / 100 mm
 AIS COMPLIANT

Model 92LSR **FLOMATIC**[®]
 Flomatic Corporation

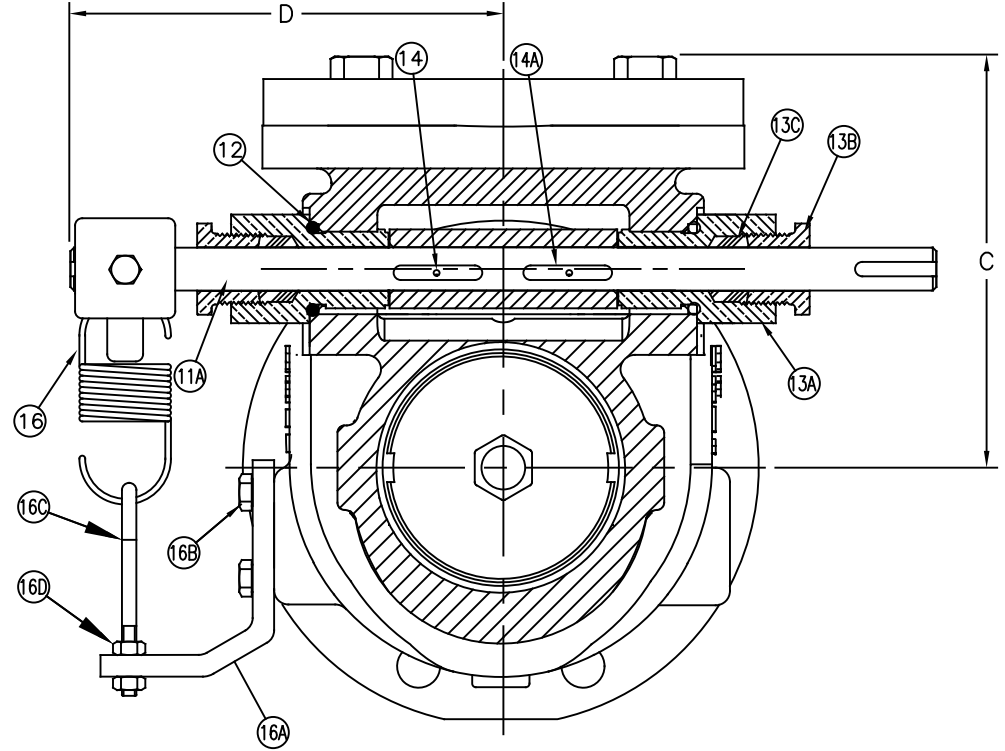
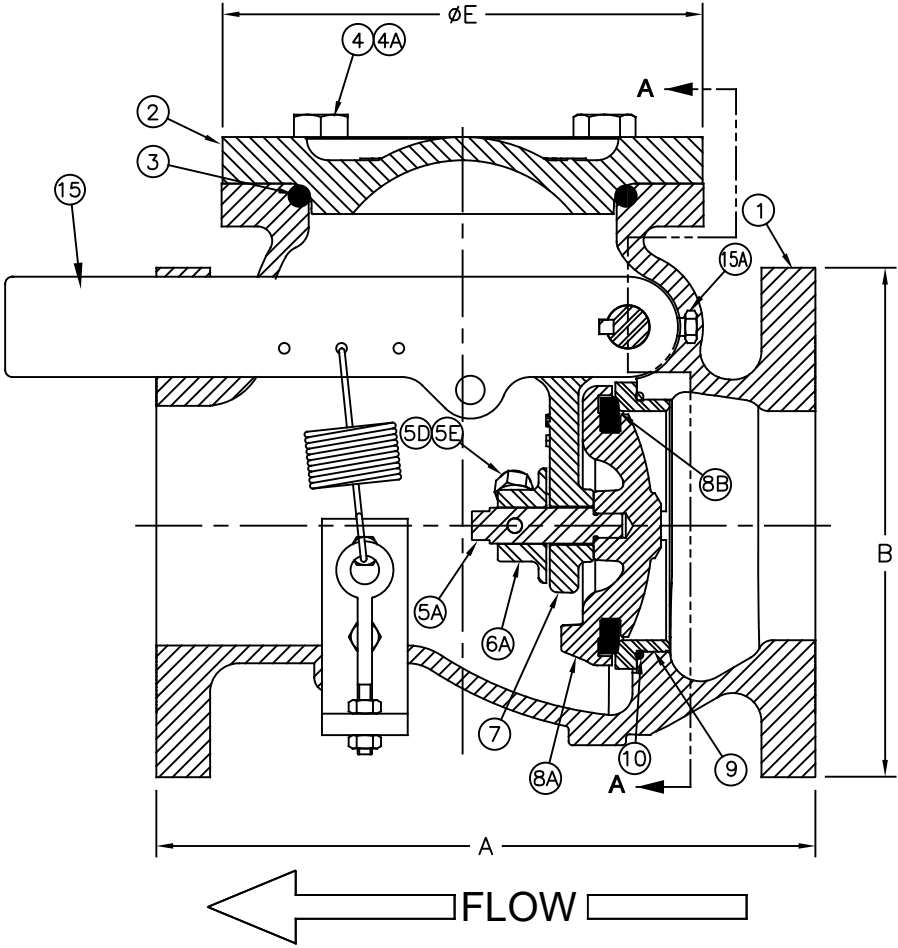

MANUFACTURED IN
 COMPLIANCE WITH
 AWWA C508 STANDARD

Flomatic Corporation can accept no responsibility for possible errors in catalogues, brochures and other printed material. Flomatic Corporation reserves the right to alter its products without notices. This also applies to product already agreed. All trademarks in this material are property of the respective companies. All rights reserved. ©2023 Flomatic Corporation. The drawings & information on this drawing sheet are the sole & exclusive property of Flomatic Corporation. Any reproduction, distribution, display or use of these drawings or information in whole or in part without written authorization of Flomatic Corporation is strictly prohibited. www.flomatic.com



Swing Check Valve

Sizes 4" / 100 mm
AIS COMPLIANT

Model 92LSR



Flomatic Corporation

Materials (Lever & Spring)



Max Temp 180°F (82°C) Max
Pressure 250psi (18bar)

Item #	Qty	Description	Material	ASTM	Item #	Qty	Description	Material	ASTM
1	1	Body*	Ductile Iron	65-45-12	11A	1	Clapper Support Shaft	Stainless Steel	17-4
2	1	Cover*	Cast Iron	A126	12	2	Bearing O'Ring	Buna-N	N6000AA
3	1	Cover O-Ring	Buna-N	N6000AA	13A	2	Shaft Support Bearing	Bronze	B140
4	4	Cover Bolt	Stainless Steel	18-8	13B	2	Packing Nut	Bronze	B140
4A	4	Cover Washer	Stainless Steel	18-8	13C	8	Teflon Packing	Teflon	-----
5A	1	Clapper Bolt	Stainless Steel	316	14	2	Set Screw	Stainless Steel	316
5D	1	Clapper Screw	Stainless Steel	316	14A	3	Key Stock	Stainless Steel	18-8
5E	1	Clapper Hex Nut	Stainless Steel	316 / Nylon	15	1	Lever Arm*	Ductile Iron	65-45-12
6A	1	Clapper Nut	Stainless Steel	304	15A	1	Bolt	Stainless Steel	18-8
7	1	Clapper Arm*	Ductile Iron	65-45-12	16	1	Spring	Stainless Steel	316
8A	1	Clapper Disc Holder*	Ductile Iron	65-45-12	16A	1	Spring Mounting Bracket*	CRS	-----
8B	1	Disc	Buna-N	-----	16B	2	Bolt	Zinc Plated	-----
9	1	Seat Ring	Stainless Steel	304	16C	1	Eyebolt	Zinc Plated	-----
10	1	Seat Ring O'Ring	Buna-N	N6000AA	16D	2	Nut	Zinc Plated	-----

* Epoxy Coated

Dimensions (150# ANSI B16.42 Flanges)

MANUFACTURED IN COMPLIANCE WITH AWWA C508 STANDARD

Size		Part #	A		B		C		D		ØE		Weight	
inch	mm		inch	mm	inch	mm	inch	mm	inch	mm	inch	mm	lbs	kg
4	100	3707LSR	11-1/2	292	8-57/64	226	7-7/32	183	7-9/16	192	8-3/4	222	119	54

Flomatic Corporation can accept no responsibility for possible errors in catalogues, brochures and other printed material. Flomatic Corporation reserves the right to alter its products without notices. This also applies to product already agreed. All trademarks in this material are property of the respective companies. All rights reserved. ©2023 Flomatic Corporation. The drawings & information on this drawing sheet are the sole & exclusive property of Flomatic Corporation. Any reproduction, distribution, display or use of these drawings or information in whole or in part without written authorization of Flomatic Corporation is strictly prohibited. www.flomatic.com

