

Swing Check Valves

Size 4" / 100 mm
 AIS COMPLIANT

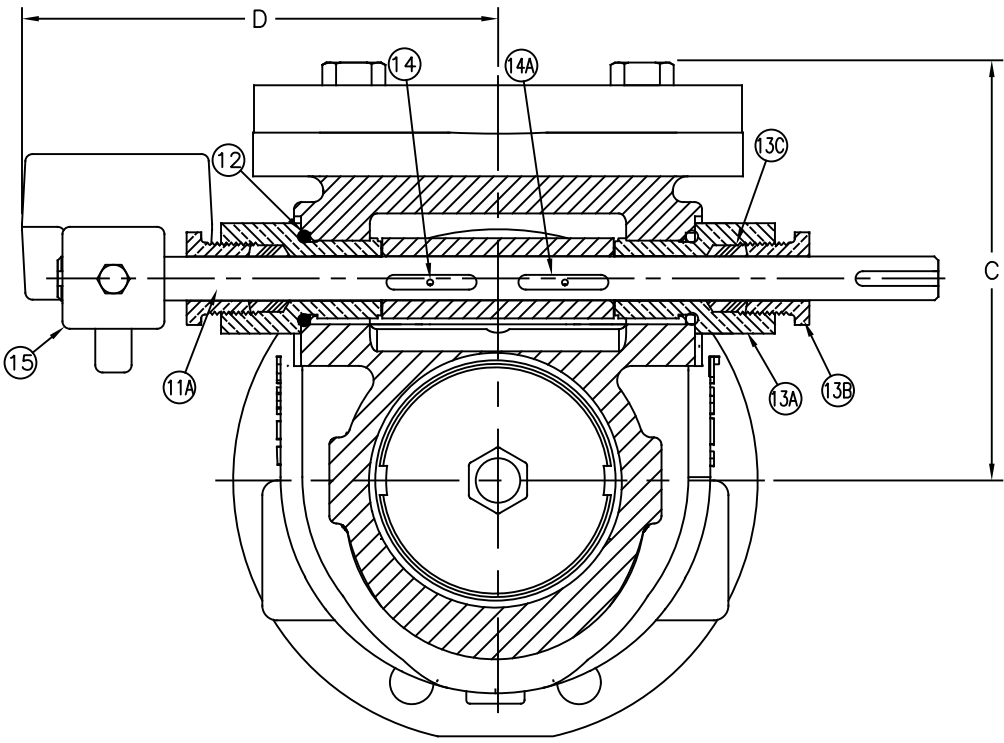
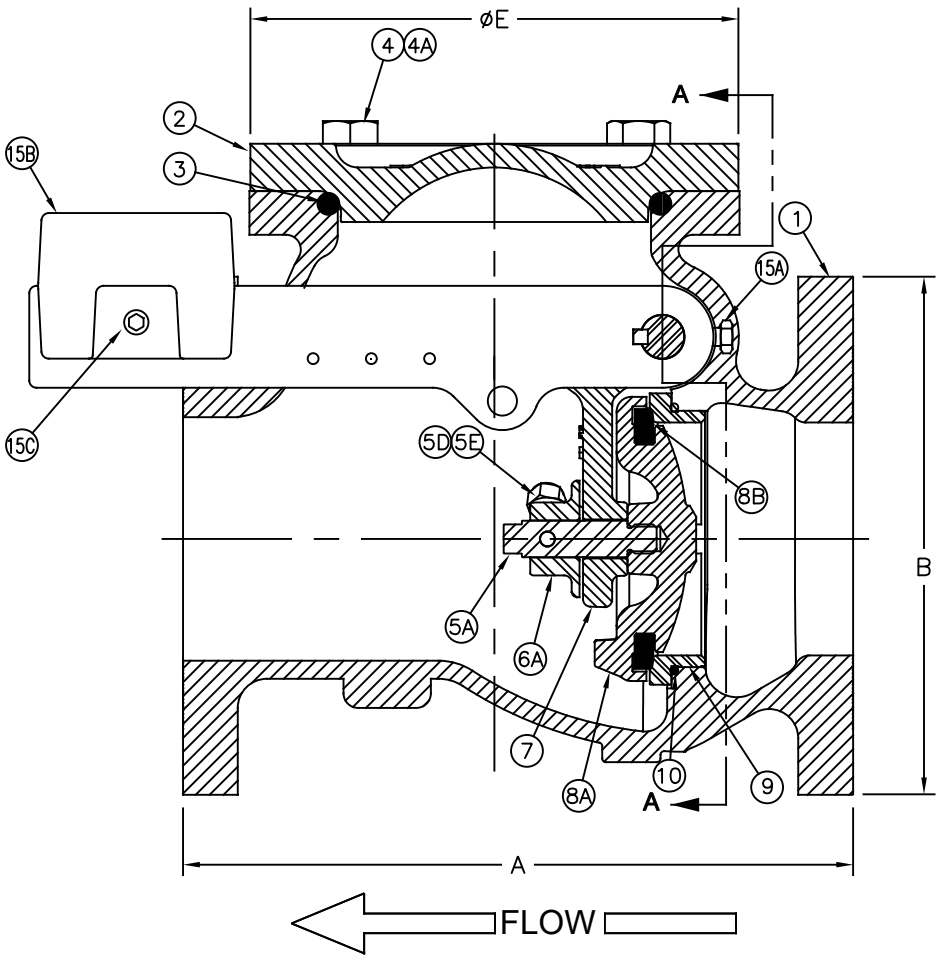

MANUFACTURED IN
 COMPLIANCE WITH
 AWWA C508 STANDARD

Flomatic Corporation can accept no responsibility for possible errors in catalogues, brochures and other printed material. Flomatic Corporation reserves the right to alter its products without notices. This also applies to product already agreed. All trademarks in this material are property of the respective companies. All rights reserved. ©2023 Flomatic Corporation. The drawings & information on this drawing sheet are the sole & exclusive property of Flomatic Corporation. Any reproduction, distribution, display or use of these drawings or information in whole or in part without written authorization of Flomatic Corporation is strictly prohibited. www.flomatic.com

Swing Check Valve

Sizes 4" / 100 mm
AIS COMPLIANT

Model 92LWR



Materials (Lever & Weight)

Max Temp 180°F (82°C) Max
Pressure 250psi (18bar)

Item #	Qty	Description	Material	ASTM	Item #	Qty	Description	Material	ASTM
1	1	Body*	Ductile Iron	65-45-12	10	1	Seat Ring O'Ring	Buna-N	N6000AA
2	1	Cover*	Cast Iron	A126	11A	1	Clapper Support Shaft	Stainless Steel	17-4
3	1	Cover O-Ring	Buna-N	N6000AA	12	2	Bearing O'Ring	Buna-N	N6000AA
4	4	Cover Bolt	Stainless Steel	18-8	13A	2	Shaft Support Bearing	Bronze	B140
4A	4	Cover Washer	Stainless Steel	18-8	13B	2	Packing Nut	Bronze	B140
5A	1	Clapper Bolt	Stainless Steel	316	13C	8	Teflon Packing	Teflon	-----
5D	1	Clapper Screw	Stainless Steel	316	14	2	Set Screw	Stainless Steel	316
5E	1	Clapper Hex Nut	Stainless Steel	316 / Nylon	14A	3	Key Stock	Stainless Steel	18-8
6A	1	Clapper Nut	Stainless Steel	304	15	1	Lever Arm*	Ductile Iron	65-45-12
7	1	Clapper Arm*	Ductile Iron	65-45-12	15A	1	Bolt	Stainless Steel	18-8
8A	1	Clapper Disc Holder*	Ductile Iron	65-45-12	15B	1	Weight*	Cast Iron	A126
8B	1	Disc	Buna-N	-----	15C	1	Set Screw	Stainless Steel	18-8
9	1	Seat Ring	Stainless Steel	304	* Epoxy Coated				

Dimensions (150# ANSI B16.42 Flanges)

MANUFACTURED IN COMPLIANCE WITH AWWA C508 STANDARD

Size		Part #	A		B		C		D		ØE		Weight	
inch	mm		inch	mm	inch	mm	inch	mm	inch	mm	inch	mm	lbs	kg
4	100	3707LWR	11-1/2	292	8-57/64	226	7-7/32	183	8-3/16	208	8-3/4	222	125	57

Flomatic Corporation can accept no responsibility for possible errors in catalogues, brochures and other printed material. Flomatic Corporation reserves the right to alter its products without notices. This also applies to product already agreed. All trademarks in this material are property of the respective companies. All rights reserved. ©2023 Flomatic Corporation. The drawings & information on this drawing sheet are the sole & exclusive property of Flomatic Corporation. Any reproduction, distribution, display or use of these drawings or information in whole or in part without written authorization of Flomatic Corporation is strictly prohibited. www.flomatic.com

